

PPG Safety Light Curtain

Installation and Operation Manual





Safety Sensors and Controls for Industry

Safety Light Curtains



Ergonomic Palm Buttons



The safest and only “control reliable” palm button that can be used as a two-hand control device!

Safety Mat Systems



Pressure-sensitive safety mats in any size, shape, cut or contour for your customized machine guarding application.

Please visit www.pinnaclesystems.com for more information on other Pinnacle Systems products or fax your request for a complete product catalog to: (412) 262-4055. Please be sure to include your company name, mailing address and a phone number with your request.

PINNACLE
S Y S T E M S , I N C.

PPG Safety Light Curtain

Installation and Operation Manual

Pinnacle Systems, Inc.
3715 Swenson Avenue
St. Charles, IL 60174

P/N: 28-047r1-8

Customer Service: 630-443-8542 (CST)
(Please have Model #, Serial #, and Software Rev # Available)

Sales and Marketing: 800-569-7697 (EST)

www.pinnaclesystems.com • sales@pinnaclesystems.com • service@pinnaclesystems.com

Proper Usage and Warnings

The information disclosed herein includes proprietary rights of the manufacturer. Neither this document nor the information disclosed herein shall be reproduced or transferred to other documents, used or disclosed to others for manufacturing purposes, or for any other purposes, except as specifically authorized in writing by the manufacturer. If this manual is supplied in connection with the sale or delivery of manufacturer's equipment, it is to be used solely for maintenance, repair or installation of such equipment.

You must read and fully understand the following information pertaining to the proper use and limitations of your PPG Series system:

- The PPG Series system must be installed by qualified personnel only.
- The PPG Series system **must not be used on full revolution presses or any machine that cannot be commanded to stop at any time.**
- You must NOT wire the Safety Output Contacts of the PPG Series system to an external relay unless you use the External Relay Checking feature built into the PPG Series system (see External Relay Check under the Optional Features section).
- The press on which the PPG Series system is installed must meet ANSI B11.1-2001 and OSHA 1910.217 regulations which include inspection and maintenance procedures that must be followed to meet these regulations. The manufacturer will NOT take responsibility for improperly maintained machinery.
- Point of operation safeguarding is spelled out in ANSI B11.19-2003 (see Appendix A). This regulation is used to determine a safe distance to place your PPG Series system.

The manufacturer takes no responsibility for operator injury as a result of improper safeguarding.

- The PPG Series system may not be able to safely stop a press which has a faulty stopping mechanism. The manufacturer cannot be held responsible for an improperly maintained or working stopping mechanism.
- The PPG Series system must be checked out before put into use; follow this manual for procedures on how to do this.
- The PPG Series system should not be modified or repaired except by qualified personnel and upon authorization of the manufacturer. Never operate machinery that is not in full working order.
- Make sure that all maintenance people, machine operators, die-setters, foremen, and supervisors have read and understand this manual.
- All procedures in this manual must be followed. The manufacturer cannot take responsibility for operation if all procedures and warnings listed in all manuals are not followed.

Warranty

Manufacturer warrants that this product will be free from defects in material and workmanship for a period of three years from the date of shipment thereof. Within the warranty period, manufacturer will repair or replace such products which are returned with shipping charges prepaid and which will be disclosed as defective upon examination by the manufacturer. This warranty will not apply to any product which will have been subject to misuse, negligence, accident, restriction, and use not in accordance with manufacturer's instructions or which will have been altered or repaired by persons other than the authorized agent or employees of the manufacturer.

Disclaimer

The provisions of the paragraph "Warranty" are the sole obligations of the manufacturer and exclude all other warranties of merchantability, expressed or implied. Further, there are no warranties which extend beyond the above warranty.

Limitation of Liability

In the event of any claim for breach of any obligations of manufacturer under any order, whether expressed or implied, and particularly in the event of any claim of a breach of the warranty or warranties contained in the paragraph "Warranty" or of any other warranties, expressed or implied which might despite the paragraph entitled "Disclaimer," be determined to be incorporated in any order the company shall under no circumstances be liable for any consequential or special damages, either in law or in equity, or for losses or expenses or claims for the same arising from the use of, or inability to use, the products of the manufacturer for any purpose whatsoever.

We have designed our equipment to the very highest performance and safety standards known to the current technological state of the art. However, the installation, usage, suitability, and fitness of our equipment for any purpose, known or unknown, is interdependent upon the performance of other equipment not manufactured, installed, or secured or maintained by the manufacturer.

We cannot and do not accept responsibility for any overall system performance when factors, such as these, are beyond our control. We will not supply individual component parts of any circuit board but will supply the individual circuit board complete. Individual receivers or emitters are available as a complete tested unit.

WARNING: The entire machine safety system must be tested at the start of every shift. Machine testing should include: (1) proper machine operation and stopping capability; and (2) verification of proper installation and settings of all point of operation guards and devices before the operation is released for production.

Table of Contents

Overview

| | |
|--------------------------|---|
| Introduction..... | 1 |
| Theory of Operation..... | 1 |
| Specifications..... | 2 |

Setup and Installation

| | |
|-----------------------------|---|
| Installation Procedure..... | 3 |
| Wiring Diagram..... | 3 |

Dimensional Information

| | |
|-------------|---|
| Pylons..... | 4 |
|-------------|---|

Standard Features

| | |
|---------------------------|---|
| Latching Relays..... | 5 |
| External Relay Check..... | 5 |

Optional Features

| | |
|-------------------------------|---|
| Auxiliary Output Contact..... | 6 |
| Cincinnati Interface..... | 6 |

Accessories

| | |
|-------------------------------------------------------------------------------------------|---|
| Cornering Mirrors..... | 7 |
| Pedestal Mounts (Model 8000)..... | 7 |
| 4 Sided Guarding with Dual Stud Guard Brackets, TRM Mirror and Model #8000 Pedestals..... | 8 |
| Swing-Arm Mounting Bracket (Model 9000)..... | 8 |

Diagnostics and Troubleshooting

| | |
|----------------------------------|----|
| Diagnostic Indicator Lights..... | 9 |
| Troubleshooting..... | 9 |
| Diagnostic Display Codes..... | 11 |

Appendix A: Regulations and Guidelines for Safe Operation

| | |
|-----------------------------------------------|------|
| ANSI Standard B11.19-2003..... | AA-1 |
| Light Curtain Test Procedure..... | AA-2 |
| Safeguarding with Mechanical Guards..... | AA-3 |
| OSHA Regulations..... | AA-4 |
| Machine Control Reliability Requirements..... | AA-5 |
| Safety Guidelines for Management..... | AA-5 |

Appendix B: Parts List

| | |
|---------------------|------|
| Receiver Pylon..... | AB-1 |
| Emitter Pylon..... | AB-2 |

(Page left blank)

Introduction

The PPG Series system is a dual redundant digital infrared point of operation guarding device which will provide a signal to stop the machine when there is entry into the guarded area. The system uses invisible infrared light to detect obstructions protruding through the guarded area. The use of infrared light provides an unobstructed view of the work area and also makes the PPG Series system insensitive to almost all ambient light conditions.

The dual redundant system basically incorporates two microprocessors, four watchdog timers, and two separate captive contact relays to assure fail-safe operation. If either microprocessor detects a failure in the system or the other microprocessor, the working microprocessor can shut down the unit. The watchdog timers assure that if the oscillator on either microprocessor is not running correctly, they can shut the system down. The special *force-guided contact relays** allow self-checking software to detect a faulty relay and shut down the unit with the redundant relay. The Diagnostics Display allows the user to better understand the current condition of the light curtain. If a fault is discovered by the light curtain, it will be displayed.

The PPG Series system operates from two pylons. The left pylon is the Emitter Pylon and the right pylon is the Receiver Pylon. Power must be supplied separately to both pylons using standard wiring procedures. The interface or stop circuit interconnection is made from the Receiver Pylon (right side).

The PPG Series system can only be used on part revolution or clutched machines which can be signaled to stop at any part of their cycle by opening an electrical circuit.

Theory of Operation

The PPG Series system is an infrared light curtain consisting of two pylons that talk to each other via an infrared channel called the Sync Channel. The Receiver Pylon transmits to the Emitter Pylon for the purpose of synchronizing the two units eliminating the need for a third box with a cable connecting the pylons together. The Diagnostics Display on the Receiver Pylon will show flashing decimal points to indicate that the Emitter Pylon is not firing.

The Receiver Pylon is the controller and the Emitter Pylon is slaved to it by the Sync Channel. The internal logic of the Receiver Pylon controls the scanning function, the detection, the output control, and the internal diagnostic functions.

When the two pylons are synchronized, the Emitter Pylon begins to scan from the top down with its infrared emitters called "data channels" or otherwise known as infrared beams. The Emitter Pylon's beams are scanned many thousands of times a second and, each time a beam is selected, its infrared emitter is pulsed. This sequential scan of infrared pulses is picked up by the Receiver Pylon which is synchronized to the scanning Emitter Pylon and recorded. If a beam is blocked by an obstruction, the control logic drops out the Output Relays and turns on the RED indicator.

The Internal Diagnostic Logic runs at the same frequency as the scan frequency so all operational components and timings are checked many thousands of times a second to insure Fail-Safe operation. The control logic in this unit has no lock-up or failed mode except for hard internal failures. No matter what conditions prevail, the unit is trying to keep all systems operational.

* *Force-Guided Contact Relays* are mechanically linked together to force both poles to maintain the same position regardless of whether the relay is energized or de-energized. This allows a welded contact to be detected by monitoring the other pole.

Overview

PPG Series Safety Light Curtain

Specifications

| Emitter and Receiver Pylons | |
|----------------------------------------------|---------------------------------------------------------------------------------------------------------------------------------------------------------|
| Input Power: | 120 +/- 10% VAC @ 50-60 Hz, 12 watts max/pylon (For a 24VDC system, consult factory) |
| Output Circuit: | Two force-guided self-checking N.O. relays in series Rated at 4 AMPS @ 120VAC Isolated (DRY) Normally Open contacts. -- -- -- 130VAC maximum |
| Fuses: | Power: 1 AMP Slow Blow (Littelfuse #313-001) Relay: 4 AMP Slow Blow (Littelfuse #313-004) |
| External Indicators: | |
| Receiver Pylon | 1) GREEN = Output Relay contacts closed (OK) 2) RED = Output Relay contacts open (NOT OK) 3) Diagnostics Display (single digit alphanumeric) |
| Emitter Pylon | RED = Sync channel alignment indicator (11-1/2" down, viewable only from inside unit) |
| Construction | Heavy duty aluminum enclosure (all welded). 14 Gauge, dust and oil tight. NEMA enclosures available (Consult factory) |
| Temperature Range: | 32° to 120° F |
| Dimensions: | See Light Curtain Dimensions. |
| Beam Spacing: | 1.5" (38mm); 3" (76.2mm); 6" (152.4mm); 12" (304.8mm) |
| Minimum Sensitivity Without Blanking: | 2" (50.8mm); 3.5" (88.9mm); 6.5" (165.1mm); 12.5" (304.80mm) |
| Response Time: | < 30 milliseconds (all lengths) |
| Scanning Frequency: | 3.6 Khz |

Setup and Installation

PPG Series Safety Light Curtain

Installation Procedure

WARNING: The entire machine safety system must be tested at the start of every shift. Machine testing should include: (1) proper machine operation and stopping capability; and (2) verification of proper installation and settings of all point of operation guards and devices before the operation is released for production.

Caution: Pylons should be mounted in a manner so that only authorized personnel can change the mounting or location.

Caution: Additional guards may be required to prevent the operator from standing between the light curtain and the point of operation.

- 1) Locate pylons so the working zone is guarded from reaching around, over, and under the PPG Series system to the point of operation or hazard zone. Mounting of pylons should be shock mounted (see Safeguarding with Mechanical Guards, Appendix A).

NOTE: For location of pylons in relation to the hazard area, refer to Federal Register 1910.217 (c) (3) (iii) (e) and Table 0-10 (both are available in Appendix A).

- 2) Determine the safety distance of the light curtain from the point of operation using the ANSI Standard B11.19-2003 (see Appendix A).
- 3) Refer to the Dimensional Information section (Page 4) for the mechanical layout of the pylons.
- 4) Refer to the Wiring Diagram section (Page 3) for electrical connections.
- 5) Power is brought to both pylons 120V AC or 24VDC (depending on the model) @ 60Hz. The Ground Terminal must be connected to a good ground connection, not conduit. A bad ground may keep the light curtain from going GREEN in an electrically noisy environment.
- 6) Refer to the Light Curtain Test Procedure section (Page AA-2) to ensure the light curtain is functioning properly.

Receiver Pylon

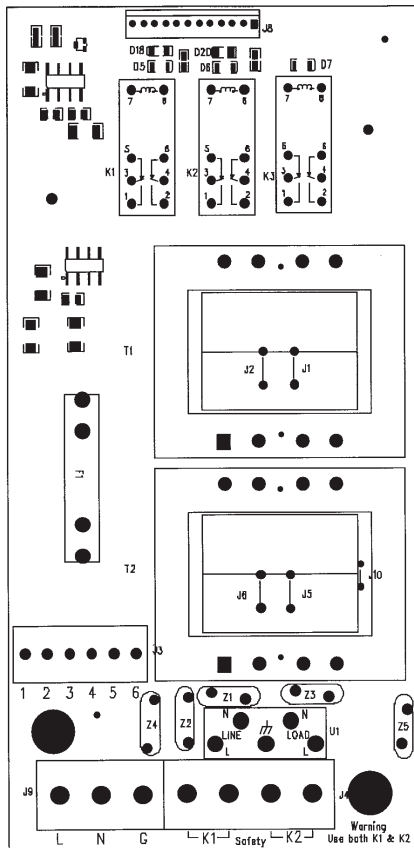

Terminal

| Terminal | Description |
|----------|------------------------------------------------------------------------------|
| 1 | Aux relay N.C. (closed when RED) (optional) |
| 2 | Aux relay common |
| 3 | Aux relay N.O. (close when Green) (optional) |
| 4 | Cincinnati Interface (Ground or Float = Normal Operation, 24vdc = Guard RED) |
| 5 | External relay checking input (must tie to terminal #6 when not in use) |
| 6 | External relay checking power |
| L,N,G | Line, Neutral, Ground |
| K1 | Safety relay (closed when Green) |
| K2 | Safety relay (closed when Green) |

Important: The Ground Terminal must be connected to a good ground connection, not conduit. A bad ground may keep the light curtain from going GREEN in an electrically noisy environment.

Emitter Pylon

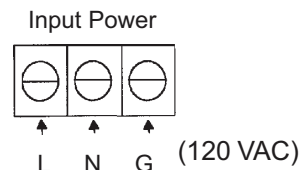

Dimensional Information

PPG Series Safety Light Curtain

Pylons

The Emitter and Receiver Pylons are mirror images; the obvious difference is that there are no lights, keyswitch, or diagnostics display on the Emitter Pylon.

All Models

| | |
|-------|---------------|
| Dim A | 3.00" (76mm) |
| Dim B | 4.25" (108mm) |
| Dim C | 1.00" (25mm) |
| Dim D | 1.87" (48mm) |
| Dim E | 0.62" (16mm) |
| Dim F | 1.00" (25mm) |
| Dim G | 1.00" (25mm) |
| Dim I | 3.25" (83mm) |
| Dim J | 0.62" (16mm) |
| Dim M | 4.25" (108mm) |

| Model | Dim H (box length) | Dim K (last to end) | Dim L (first to last beam) |
|--------|-----------------------|------------------------|-------------------------------|
| PPG-24 | 28.87" (733mm) | 1.87" (48mm) | 25.22" (641mm) |
| PPG-30 | 36.25" (921mm) | 2.87" (73mm) | 31.52" (801mm) |
| PPG-36 | 42.12" (1070mm) | 2.87" (73mm) | 37.82" (961mm) |
| PPG-42 | 48.37" (1229mm) | 2.87" (73mm) | 44.12" (1121mm) |
| PPG-48 | 54.75" (1391mm) | 2.87" (73mm) | 50.42" (1281mm) |
| PPG-60 | 67.25" (1708mm) | 2.87" (73mm) | 63.02" (1601mm) |
| PPG-72 | 79.75" (2026mm) | 2.87" (73mm) | 75.62" (1921mm) |
| PPG-84 | 91.75" (2330mm) | 2.87" (73mm) | 88.22" (2241mm) |
| PPG-96 | 103.75" (2635mm) | 2.87" (73mm) | 100.82" (2561mm) |

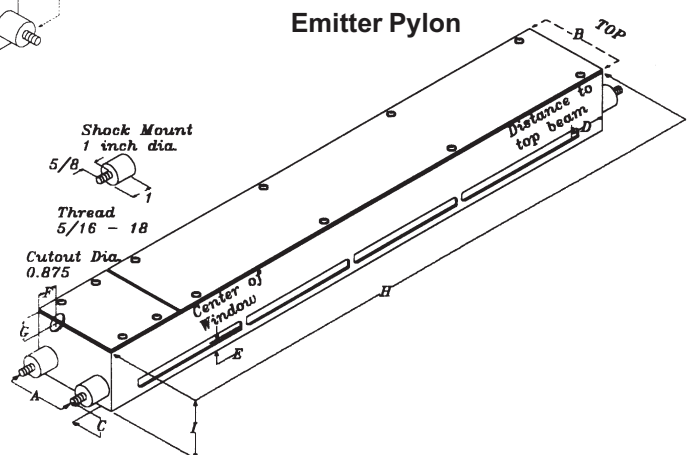
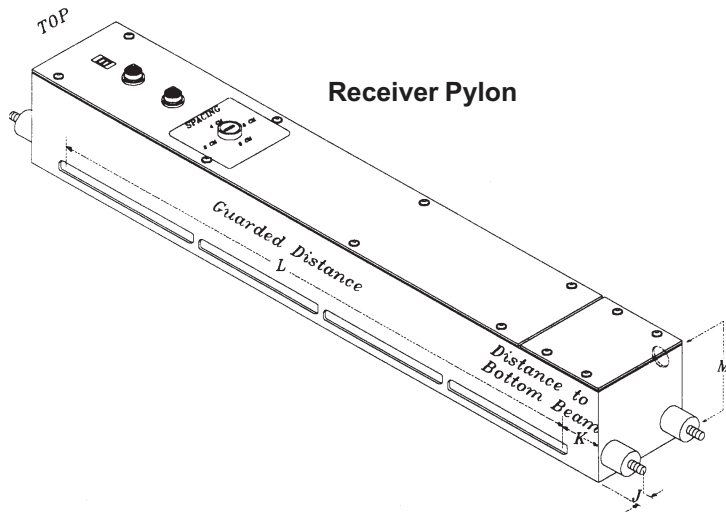

Latching Relays

(standard on Perimeter guards)

The Latching Relays option causes the light curtain to latch in a RED condition after a RED condition is encountered (penetration). The display reads "8". This is used for guarding an area against intrusion, otherwise, without this option the light curtain would only stay RED as long as the intrusion was blocking the light curtains' field of view. A push button is used to reset the curtain and the software requires that the button be cycled by clearing the curtain.

To Install a remote reset: Remove the cover of the Receiver Pylon (the one with the lights). You will find two, four-pin connectors labeled U204 & P101.

P101 should have a plug installed already. Remove this plug and you will de-activate the latching relay feature. This allows you to align the curtain. Put back the plug when you are finished aligning the curtain.

U204 is where you hook up your reset button to the outer pins 1 & 4.

External Relay Check

The External Relay Check option allows the PPG system to monitor an external relay using the external relay's secondary set of isolated contacts, provided that they are N.C. captive contacts. This secondary captive contact will maintain an identical position to the primary captive contact. When the Curtain is Green the internal safety relays are energized and closed. This energizes the external relays which close the primary contacts and open the secondary contacts. Failure of the External Relay contact (welded closed) will show up on the Diagnostics Display as a Code 5 and the internal relays will shut down and lock out. You must cycle power to clear the fault. You must tie Terminal 5 to 6 when not being used (see Wiring Diagram and Terminals 5-6, Page 3). This option is built in and comes with Terminal #5 tied to Terminal #6.

To use this feature you must wire Terminal #6 in series with the N.C. contacts of your 2 external force guided relays and back to Terminal #5.

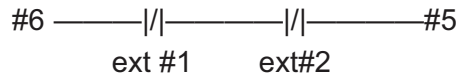

Optional Features

PPG Series Safety Light Curtain

Auxiliary Output Contact

The Auxiliary Output Contact option provides either a N.O. or N.C. isolated (DRY) contact output to signal a RED condition on the light curtain. This output is used in conjunction with the standard pair of output relays that get wired up to the safety circuit of your equipment (i.e., stop circuit). The standard relay output is monitored, but **the Auxiliary Output Contact is NOT monitored and should only be used as a signal line** (i.e., for additional PLC monitoring).

The Auxiliary Output Contact is Form C (N.O. & N.C.) and can handle 5Amps @ 125V AC (not fused). See Wiring Diagram and Terminals 1-3 for proper usage, Page 3.

Cincinnati Interface

The Cincinnati Interface option allows an external device (i.e., Cincinnati Press or PLC) to override the light curtain and initiate a RED condition and open up the standard output relay contacts. This is provided to allow a PLC to determine if the light curtain is still capable of shutting down the safety control circuit. **This option must be ordered before you should attempt to attach anything to Terminal #4.** If this option is installed, you must tie Terminal #4 to Terminal G when not in use.

The external device must provide a 24VDC output to the light curtain to initiate this RED condition. Do not exceed 24VDC or damage will occur to the internal circuitry of the PPG. **If you have this option, but for some reason do not use it, you must ground the interface terminal.** Failure to do so could cause the guard to stay in a RED condition (see Wiring Diagram and Terminal 4, Page 3).

Cornering Mirrors

Through the use of cornering mirrors, multiple sides or work envelopes can be guarded which enhance safety and reduce down-time related to mechanical and electrical interlock systems.

Include a **5% reflectivity loss per mirror** when calculating total scanning distance of light curtain.

NOTE: Mirrors are surface coated. Wipe surface using only a damp, clean, soft 100% cotton cloth. To replace: remove the end bracket, slide out the mirror with the gasket.

| Model | Dim A (hole to hole) | Dim B (mirror) | Dim C (total) |
|-------|----------------------|-----------------|-----------------|
| TRM12 | 19.45" (494mm) | 18.25" (464mm) | 20.50" (521mm) |
| TRM18 | 25.45" (646mm) | 24.25" (616mm) | 26.50" (673mm) |
| TRM24 | 31.45" (799mm) | 30.25" (768mm) | 32.50" (825mm) |
| TRM30 | 37.45" (951mm) | 36.25" (921mm) | 38.50" (978mm) |
| TRM36 | 43.45" (1104mm) | 42.25" (1073mm) | 44.50" (1130mm) |
| TRM42 | 49.45" (1256mm) | 48.25" (1226mm) | 50.50" (1282mm) |
| TRM48 | 55.45" (1408mm) | 54.25" (1378mm) | 56.50" (1435mm) |
| TRM60 | 67.45" (1713mm) | 66.25" (1683mm) | 68.50" (1739mm) |
| TRM72 | 79.45" (2018mm) | 78.25" (1988mm) | 80.50" (2045mm) |

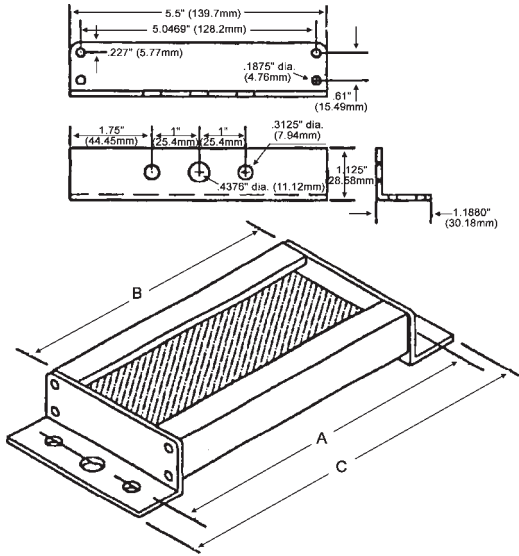

Note: See Page 8 for Mirror/Pedestal setup

Pedestal Mounts (Model 8000)

The heavy duty, all welded steel pedestal floor mounts can be used for mounting either the PPG Series system or cornering mirrors. Sliding mounts on the pedestal are of universal design and are supplied standard. Unique floating base on pedestal is designed to compensate for uneven floors.

Pedestals must be bolted to the floor, they must not be movable!

- 1) Sliding Mounts supplied
- 2) Standard height - 72" - Model 8000
Optional height - 96" - Model 8096
- 3) Painted OSHA yellow
- 4) Pedestal - 12 gauge steel
Base Plate - 1/4" steel plate

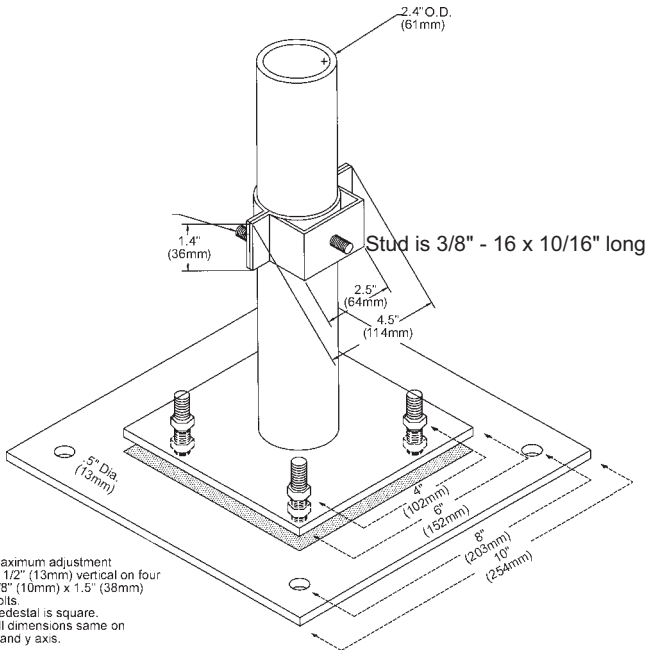

Accessories

PPG Series Safety Light Curtain

4 Sided Guarding with Dual Stud Guard Brackets, TRM Mirrors and Model #8000 Pedestals

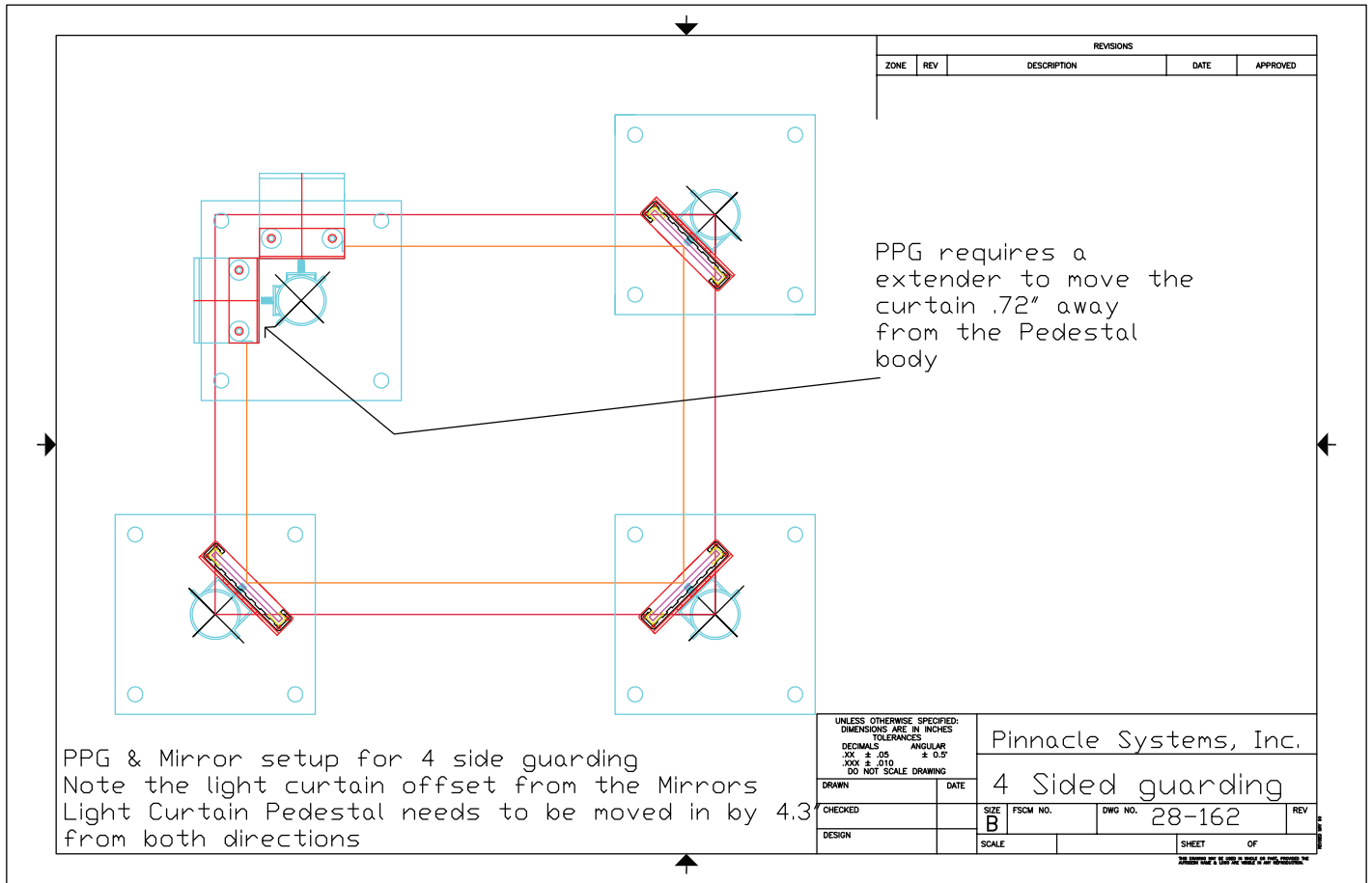

Swing-Arm Mounting Bracket (Model 9000)

Excellent method of mounting light guard for press brakes or when light guard is to be moved for die setups or machine maintenance. Model 9000 consists of three 180° pivot points along with light guard diagonal movement capability for virtually unlimited light guard positioning. Two-inch square tubing 3/16" thick painted OSHA yellow which mounts directly onto the machine housing and makes for a heavy duty yet versatile mounting bracket.

Specify dimensions "B" & "C"

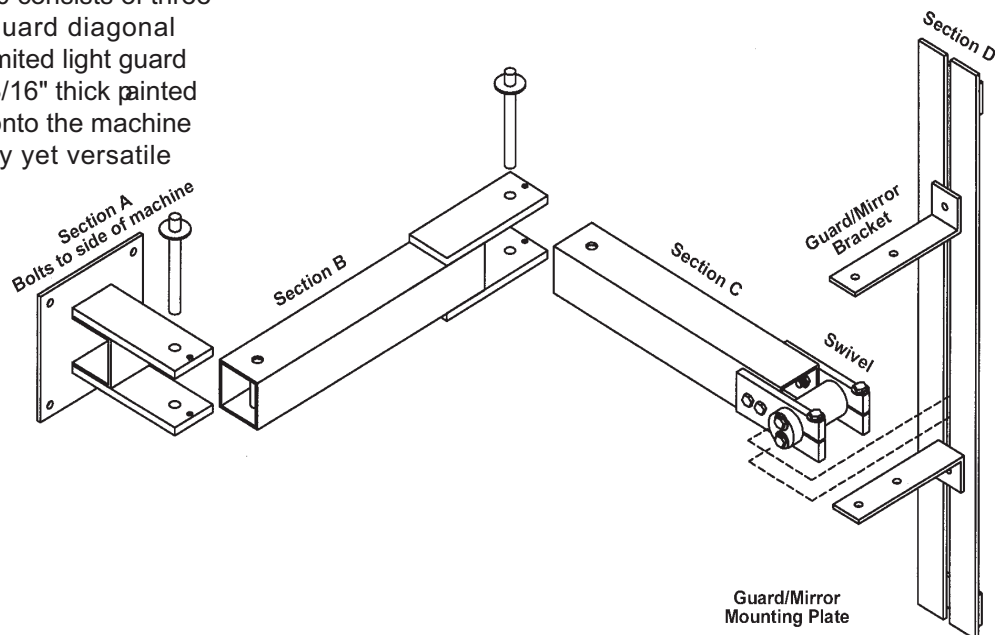

Diagnostic Indicator Lights

Emitter Pylon. The *Sync Channel* light is located on the Emitter Pylon and is visible 1 1/2 inches down from the top of the enclosure inside the pylon (it cannot be viewed from outside the pylon, the cover must be taken off). The normal condition of this light is out. It will illuminate only if the top channel is blocked or not lined up, and briefly for a 1/2 second at the time power is applied to both pylons.

There are internal indicator lights located inside at the top of the Emitter Pylon to indicate proper internal voltages. These are:

- | | | |
|----------|---------|-----|
| 1) GREEN | - 15VDC | D19 |
| 2) RED | + 15VDC | D18 |
| 3) AMBER | + 10VDC | D17 |

All three lights must be illuminated for proper system operation.

Receiver Pylon. There are internal indicator lights located inside near the top of the Receiver Pylon on the upper printed circuit board, lower right side, to indicate proper internal voltages. These are:

- | | | |
|----------|---------|-----|
| 1) GREEN | - 15VDC | D22 |
| 2) RED | + 15VDC | D21 |
| 3) AMBER | + 5VDC | D20 |

All three lights must be illuminated for proper system operation.

Slave Microprocessor. Four more LED's are located inside at the very top of the upper printed circuit board in the Receiver Pylon, these indicators explain the condition of the Slave Microprocessor. These are:

- | | |
|-----------|----------------------------------------------|
| 1) GREEN | OK |
| 2) YELLOW | Blocked DATA CHANNEL |
| 3) RED | External fault (slave detected a fault) |
| 4) RED | Internal fault (slave microprocessor is bad) |

You may notice flickering in these LEDs, this is because the slave is much faster than the system it is monitoring.

If either RED LED stays lit, then a fault occurred and the unit must be checked out.

Troubleshooting

NOTE: When light curtain is powered up, the Diagnostics Display will count down four times with the decimal points on. This indicates that the microprocessors are functioning correctly. If you do not see this happening, your light curtain unit must be returned for repair.

PROBLEM: Light curtain locks up / light curtain resets when penetrated.

- Cause(s):**
- 1) Check line voltage on the input power terminals and make sure that it is within this units' specifications. Low voltage can keep the output relays from closing and will keep the guard in a RED condition and/or cause the microprocessors to keep resetting.
 - 2) Check the voltage level on the output relay contact terminals—it should not exceed 130V AC. A higher voltage will cause the internal MOV noise filtering devices to short to ground when the output relay contacts close which will cause the unit to lock up in a RED condition.
 - 3) Check for noise on lines at the power terminals and/or output relay terminals. Dirty line voltage can cause the microprocessors to reset and/or the unit to lock up in a RED condition.

- Cure(s):**
- 1) If line voltage is low, you must find a way to boost the voltage level.
 - 2) The manufacturer will provide you with MOV components which you can then place on the power lines of any device that may be causing noise on the line voltage (i.e., Solenoids, motors, etc.)

PROBLEM: Light curtain gets a code "C" on the display or sometimes won't go GREEN.

- Cause(s):** Examine the locations of all light curtains around the troubled unit. When one unit can see another unit (i.e., Receiver Pylon of unit 1 can see Emitter Pylon of unit 1 as well as Emitter pylon

Diagnostics and Troubleshooting

PPG Series Safety Light Curtain

of unit 2), synchronization between Emitter and Receiver pylons is broken. The light curtain will either display a code "C" upon power up, or stay in a RED condition.

Test: Run troubled light curtain with other light curtains (in view) turned off. The troubled light curtain should now work correctly.

Cure(s):

- Try re-adjusting the locations of all light curtains. A slight tilt of a pylon can clear up the problem.
- Put up partitions or blinders between light curtains.

PROBLEM: Light curtain does not go GREEN.

Cause(s): Many.

Test: Try running the unit with the pylons butted up against each other. The unit should now go GREEN. If it doesn't, the unit should be returned for repair. If it went GREEN, the beams may be mis-aligned. You may be running the unit beyond its aligned distance. There is a 5% penalty for every mirror you use.

Cures: *Both pylons may require slight adjustments even after being mechanically aligned to get the unit to go GREEN.* The PPG Series system uses infrared light emitting diodes (IRLED's) as a means of detecting obstructions found in the field of view between the two pylons. These IRLED's are spaced at regular intervals down the entire length of the curtain. The infrared light fans out like a flashlight beam, not like a laser beam. As the infrared light fans out, it loses strength, so the farther apart the light curtain pylons are, the weaker the signal. Proper mechanical alignment of the pylons should allow the light curtain to function properly. However, some problems can still occur, but can be cleared up upon further explanation. They are as follows:

Connections. Check for proper connections and voltage levels before proceeding further.

Vibration. The PPG Series system allows for a certain amount of mechanical play once aligned, but sometimes the units are installed so movement in a particular direction will cause the unit to go RED. Over a period of time, vibration may cause the mounting brackets to shift slightly and in some cases the unit may become misaligned to the point that it will not go GREEN anymore. To determine this, loosen up the mounts and re-adjust both pylons one at a time until the unit goes GREEN. If you have mirrors, you may have to re-adjust them too.

Obstructions: Look for objects that are close to or in the field of view of the light curtain. Once you have determined a location to mount your light curtain, you must be careful of nearby obstructions (objects that are not mechanically in the line of sight of the light curtain pylons but fall within about 1/2 inch). Although these objects may not be mechanically in the line of sight, the light curtain may fail to go GREEN because it detected the object as an obstruction. The reason for this is because the nearby obstruction reduces the amount of infrared light that gets by the object and the Receiver Pylon fails to see the beam and stays RED.

Use of Mirrors. The use of mirrors to go around corners creates a penalty in distance and adjustment play. When you use mirrors, some of the infrared light passes through the surface coating of the mirror. This decreases the total distance the light curtain can go (about 5% per mirror). If the mirror was not surface coated, the loss would be even greater and parallax view would make it very difficult to align.

Upon determining the location of the mirrors, you must allow for some adjustment. Because angle of incidence equals angle of reflection, a small error in location of any mirror will throw off the beams as they pass to the next mirror and may be compounded when passed again to a third mirror. Even though you may have determined

Diagnostics and Troubleshooting

PPG Series Safety Light Curtain

that mechanically the beams should be hitting the center of the mirror, the beams may hit the next mirror slightly off center due to inaccuracies between the optical and mechanical centers.

Once the mirrors and pylons are placed in mechanical alignment, start adjusting the mirror closest to the Emitter Pylon. This will affect the location that the beams strike the next mirror, and so on.

Nearby obstructions may fall into the field of view if the mirrors are not correctly adjusted.

Other Light Curtains. The infrared beams that leave the Emitter Pylon spread out like a flashlight and sometimes may end up hitting the Receiver Pylon of another pair of light curtains. This can sometimes throw off both sets of light curtains and keep one or both sets RED.

To determine if this is happening, turn off all light curtains and try one set at a time. You may have to place a blinder to keep one unit from seeing another.

Reflections. Highly reflective material near the light curtain can cause the infrared light to bounce around and keep the unit RED. To determine if this is happening, temporarily cover up any reflective material (i.e., polished metal) and re-align the pylons and the unit should go GREEN. You have to paint the offending object to clear up the problem.

Diagnostic Display Codes

.1. Blinking If the decimal points on the display are blinking, this indicates that the computers have not received a single beam from the Emitter Pylon. This means that either the Emitter Pylon is not on, you are blocking the sync (top) channel, a bad Emitter Pylon, or an alignment problem.

0 Clear

Definition: No obstructions found.

Status: GREEN, output relays energized.

Reason: Nothing wrong.

1 1 Beam Broken/Alignment Problems

Definition: The light guard was triggered when at least one beam was detected broken.

Status: RED, fail safe relays off.

Reason(s):

- 1) Obstruction of one or more beams during normal light curtain operations.
- 2) If no obstruction is observed, then light curtain is misaligned.
- 3) Emitter Pylon is not transmitting.
- 4) Sync Channel not firing.

Cure(s):

- 1) Remove all obstructions.
- 2) Place Auto Blank option in OFF/RESET position.
- 3) If the Sync LED is off and the display still reads 1, then try and realign the light curtain's position until you get a GREEN condition.
- 4) If the Sync LED is on, then try aligning the pylons to get the Sync LED to go out. Placing the pylons close together will prove if the units will ever go GREEN.

Important: The Ground Terminal must be connected to a good ground connection, not conduit. A bad ground may keep the light curtain from going GREEN in an electrically noisy environment.

Diagnosics and Troubleshooting

PPG Series Safety Light Curtain

2 2 Beams Broken

Definition: The light guard was triggered when at least two beams were detected broken.

Status: RED, fail safe relays off.

Reason(s):

- a) If no obstruction is observed, then light curtain is misaligned.
- b) Emitter Pylon is not transmitting.

Cure(s): Remove all obstructions. If display still reads 1 or 2, then realign light curtain.

3 3 Beams Broken

Definition: At least three beams were detected broken.

Status: RED, fail safe relays off.

Reason(s):

- a) If no obstruction is observed, then light curtain is misaligned.
- b) Emitter Pylon is not transmitting.

Cure: Remove all obstructions. If display still reads 1, 2, or 3, then realign light curtain.

4 4 Beams Broken

Definition: The light guard was triggered when at least four beams were detected broken.

Status: RED, fail safe relays off.

Reason(s):

- a) If no obstruction is observed, then light curtain is misaligned.
- b) Emitter Pylon is not transmitting.

Cure(s): Remove all obstructions. If display still reads 1, 2, 3, or 4, then realign light curtain.

5 Relay Fault: One On / One Off

Definition: There are two captive contact relays inside the light curtain of which one is open and the other is closed. This condition should never occur because the system is designed to always operate both relays together.

Status: Both the RED and GREEN lights are on but the output circuit is broken and the light curtain has failed safe.

Reason(s):

- a) Contact on one relay welded together keeping it closed or other internal mechanical relay malfunction.
- b) Fault in one of the driver IC's causing either a relay to remain on or off.
- c) Jumper settings on watchdog timer IC's are incorrectly set.
- d) Fault in one of the two watchdog timers controlling the driver IC's which require a clock signal of a period less than 1 mSEC.
- e) Fault in the gate chip between the Master and Slave computers which allows the Slave computer to override the Master and turn a relay on.
- f) Error condition exists within one of the two computers.
- g) The two computers disagree on whether to turn the relays off.
- h) Line voltage levels too low to activate one of the two relays.

Cure(s): Only reason a) can be checked by user all other reasons can only be checked by authorized trained personnel.

Diagnostics and Troubleshooting

PPG Series Safety Light Curtain

6 Relay Fault: Both off (should be on)

Definition: Both relays were detected as OFF when they were signalled by the computer to turn on.

Status: Red light on, fail safe.

- Reason(s):**
- a) Internal mechanical relay problem.
 - b) Jumpers on watchdog timer IC' s are incorrectly set.
 - c) Slave has legally overridden the Master because it believed the current conditions require the relays to be off.
 - d) Line voltage levels too low to activate either relay.

Cure(s): Only reason a) can be checked by user all other reasons can only be checked by authorized trained personnel.

8 Latching Relay Active

Definition: Any time the light curtain field is penetrated, safety relays will open up and lockout. The light curtain will not clear until the Latching Reset button is pushed (see Page 5).

Status: RED condition

- Reason(s):**
- a) initial power up.
 - b) light curtain field broken

9 Internal Ram Fault

Definition: When the light curtain self-tests, it exercises all of its internal ram locations to make sure that they all store data properly. Upon testing, one or more memory locations failed this test.

Status: RED light, fail safe relays open.

- Reason(s):**
- a) Reset circuitry failed to respond to a glitch in the power supply line.
 - b) Bad ram.
 - c) Bad ground.

Cure(s): Check grounds, power down the light curtain for one minute and try again. If

this does not work, the unit must be serviced by authorized personnel.

A Master cannot talk to slave computer

Definition: The Master waits for the Slave to communicate between each scan of the light curtain and will time-out if it can't complete its communication.

Status: RED light, fail safe relays open.

- Reason(s):**
- a) Faulty microprocessor chip(s).
 - b) Noise on power line causes one of the two microprocessors to reset and fall out of sync with the other.
 - c) Intermittent drop in line voltage.

Cure(s): If the problem is intermittent, then it is noise. Tap power for the Receiver Pylon head of all other devices that cause noise (i.e., solenoids, motors) so that it gets cleaner power. Also, monitor line voltage for any intermittent drops.

B Data disagreement with the slave unit

Definition: The Master has linked up with the slave properly, but the Slave sees different data than the Master.

Status: RED light, fail safe relays open.

- Reason(s):**
- a) information on switch positions differ.
 - b) values of special registers differ.

Cure(s): Check ground connections. The unit must be serviced by authorized personnel.

C External infrared source detected at startup

Definition: Infrared signals detected when the right side Emitter Pylon was not signaled to transmit.

Status: RED light, fail safe relays open.

Reason(s): External pulse of infrared light from a strobe or another light curtain was detected during self-testing.

Diagnostics and Troubleshooting

PPG Series Safety Light Curtain

Cure(s): Turn off all other light curtains in the entire area and try the curtain again. It is probably another nearby light curtain emitter throwing this light curtain out of sync. You may need to reverse their position by exchanging the Receiver and Emitter pylon with each other so it fires its beams in the other direction.

D Internal Short/Open

Definition: Between each scan the Master looks at the output of each receiver circuit in turn. Should an improper signal level occur, this code is displayed.

Status: RED light, fail safe, relays open.

- Reason(s):**
- a) Problem in any one of the cable connections inside the Receiver Pylon.
 - b) Short in one of the phototransistors.
 - c) Open in one of the comparators.
 - d) External infrared source of long duration.
 - e) Beam in transmitter pylon left on.

Cure(s): Check all cables inside the Receiver Pylon for bent pins or cold solder joints.

E Beam and/or board select line failure

Definition: The Master has linked up with the slave properly, but the Slave sees different data than the Master.

Status: RED light, fail safe relays open.

- Reason(s):**
- a) Board select chip bad.
 - b) Beam select chip bad.
 - c) Master has problem with data port select lines.
 - d) Slave has problem with reading select lines.
 - e) Short or open on PCB.

Cure(s): Check ground connections. The unit must be serviced by authorized personnel.

F Clock/Code Failure

Definition: The onboard watchdog timer sensed a clock malfunction or a failure in the execution of the code. Upon initial power up, the Diagnostic Display should count backwards from 'F.' to '0.' to indicate that its clock is running. If you do not see this happening when powering up, the clock or computer chip is bad. If you see it happen and then get this code, a glitch has caused a software code failure.

Status: RED light, fail safe relays open.

- Reason(s):**
- a) Voltage levels too low for operation.
 - b) Crystal bad.
 - c) Power surge caused code to executed improperly.
 - d) Reset circuit glitch.
 - e) Computer bad.

Cure(s): Check for low line voltage. If the line voltage drops below 105VAC (even for just a second) the guard could lock up and display this code.

Appendix A:

Regulations & Guidelines for Safe Operation

PPG Series Safety Light Curtain

ANSI Standard B11.19-2003

Formula for calculating safety distance of light curtains from hazardous point of operation.

The effective sensing field of the device shall be located at a distance from the nearest recognized hazards such that the operator or others cannot reach the hazard with a hand or other body part before cessation of motion during the hazardous portion of the machine cycle.

The point at which a device responds to an intrusion may vary. The devices should be located or adjusted such that the device always responds to the intrusion at or prior to the safety distance. Care should be exercised when installing the device to ensure that it does not detect false signals from other devices in the area.

Usually the electro-optical presence-sensing device is used in a manner that provides a protected zone in front of the primary work area with auxiliary devices or guards used to protect secondary access areas. In some cases, however, mirrors may be used in conjunction with the device to provide 2-, 3-, or 4-sided protection.

The machine stop time should be measured with the machine running at its fastest speed with its heaviest die or tooling and the stop time being measured at the 90° position in the downstroke.

The following formula should be used when calculating the safety distance:

$$D_s = K \times (T_s + T_c + T_r + T_{bm}) + D(pf)$$

- D_s = Minimum safety distance between the device and the nearest point of operation hazard (in inches).
- K = Hand speed constant. This value has been determined by various studies and, although these studies indicate speeds of 63 in/sec to over 100 in/sec, they are not conclusive determinations. The employer should determine this value by considering all factors, including physical ability of the operator
- T_s = Stop time of the machine tool measured by a stop time measurement device.
- T_c = Response time of the control system (usually is taken care of by the measurement device).
- T_r = Response time of the presence-sensing device and it's interface, if any, as stated by the manufacturer or measured by the employer.
- T_{bm} = Additional time allowed for the brake monitor to compensate for variations in normal stopping time.
- $D(pf)$ = Depth Penetration Factor. Added distance as indicated by Figure 2. The minimum object sensitivity is stated by the manufacturer. If a Floating Blank is used, use the Dpf numbers found on Tables 2 and 3.

Figure 2: Minimum Object Sensitivity and D(pf)

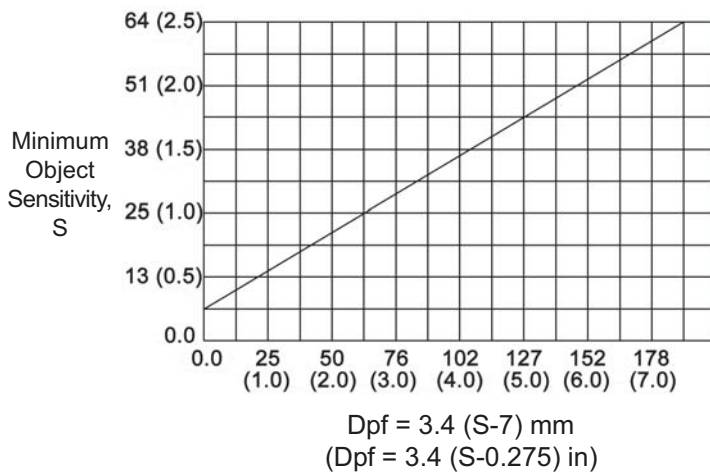

Penetration factor, Dpf, for presence-sensing devices used in a vertical application with object sensitivity less than 64 mm (2.5 inches)

Dpf, the distance added to the safety distance due to the penetration factor compensates for varying object sensitivities of electro-optical presence-sensing devices.

When blanking features are used and when the blanked area is not completely filled by the workpiece or part, or by mechanical guarding, the minimum object sensitivity can be calculated as:

$$\text{Object sensitivity} = \text{size of the blanked area plus minimum object sensitivity without blanking.}$$

Once this value is found, then determine Dpf.

If the entire blanked area is filled with mechanical guarding or other fixed material or guards, use the device's object sensitivity to determine Dpf.

Appendix A:

Regulations & Guidelines for Safe Operation

PPG Series Safety Light Curtain

Light Curtain Test Procedure

Use a dowel rod (or similar object) with a diameter equal to the M.O.S. (Minimum Object Sensitivity) of the guard you are testing. Move the rod through the field of the curtain (i.e. top to bottom for vertically mounted curtains). Repeat this test close to the Emitter pylon, close to the Receiver pylon, in the middle between the pylons, and most importantly in front of the operator position.

Make sure the curtain indicates a “Blocked” condition (RED light) when the rod is in the field of the curtain.

Check and make sure the machine cannot move when the curtain shows “Blocked”. If the machine can operate while the curtain shows a “Blocked” condition, then re-examine your wiring.

NOTE: Always use both safety relays in your STOP circuit(s).

If the curtain does not show “Blocked” when the rod is in the field: Check to make sure the rod is truly in the curtain’s field, and re-check the curtain’s Minimum Object Sensitivity (including AutoBlank and Floating blank options that change the M.O.S.).

Infrared light from the curtain may be reflecting around the rod due to reflective material too close to the curtain’s field. In this case, you will have to move the curtain pylons back away from the reflective material and repeat the test over again. The curtain’s power level can also be reduced by the factory.

Appendix A:

Regulations & Guidelines for Safe Operation

PPG Series Safety Light Curtain

Safeguarding with Mechanical Guards

When a light system is used to protect the operator or passerby from penetration, it must be mounted and properly sized (grid length) so it is impossible to reach under, around, or over into the hazardous point of operation zone. Infrared light systems normally guard the front or feed area of a machine. The sides or the areas where the light screen does not guard must be guarded by some other means.

If the position of the safety light curtain will allow the operator or others to place themselves between the sensing field and the hazardous area, auxiliary guards or devices such as a safety mat, barrier guards or devices should be used in conjunction with the safety light curtain to prevent the operator or others from exposure to the hazardous area.

If mechanical guards such as: polyurethane, expanded or perforated metal, hairpins, etc. are used to guard these areas, the opening must comply with the OSHA safety distance in relationship to the openings.

After installation of point of operation guards and before a job is released for operation, a check should be made to verify that the guard will prevent the operators hands from reaching into the point of operation or any hazard zone.

Table 0-10: Mechanical Guards

| Distance of opening from point of operation hazard (inches) | Maximum width of opening (inches) |
|-------------------------------------------------------------|-----------------------------------|
| 1/2 to 1-1/2 | 1/4 |
| 1-1/2 to 2-1/2 | 3/8 |
| 2-1/2 to 3-1/2 | 1/2 |
| 3-1/2 to 5-1/2 | 5/8 |
| 5-1/2 to 6-1/2 | 3/4 |
| 6-1/2 to 7-1/2 | 7/8 |
| 7-1/2 to 12-1/2 | 1-1/4 |
| 12-1/2 to 15-1/2 | 1-1/2 |
| 15-1/2 to 17-1/2 | 1-7/8 |
| 17-1/2 to 31-1/2 | 2-1/8 |

The table above shows the distances that guards should be positioned from the nearest point-of-operation hazards.

The various openings are such that for average size hands, an operator's fingers will not reach the point of operation.

After installation of point-of-operation guards and before a job is released for operation, a check should be made to verify that the guard will prevent the operator's hands or other body parts from reaching the point of operation.

Appendix A: Regulations & Guidelines for Safe Operation

PPG Series Safety Light Curtain

OSHA Regulations

1910.217 (C) (3) (iii)

Safeguarding the Point of Operation

(iii) A presence sensing point of operation device shall protect the operator as provided in paragraph (c) (3) (i) (a) of this section, and shall be interlocked into the control circuit to prevent or stop slide motion if the operator's hand or other part of his body is within the sensing field of the device during the downstroke of the press slide.

- (a) The device may not be used on machines using full revolution clutches.
- (b) The device may not be used as a tripping means to initiate slide motion.
- (c) The device shall not be constructed so that a failure within the system does not prevent the normal stopping action from being applied to the press when required, but does prevent the initiation of a successive stroke until the failure is corrected. The failure shall be indicated by the system.
- (d) Muting (bypassing of the protective function) of such device, during the upstroke of the press slide, is permitted for the purpose of parts ejection, circuit checking, and feeding.
- (e) Refer to ANSI B11.19-2003 for calculating safety light curtain distance from the point of operation.
- (f) Guards shall be used to protect all areas of entry to the point of operation not protected by the presence sensing device.

1910.217 (C) (3) (iii)

Additional requirements for safeguarding

Where the operator feeds or removes parts by placing one or both hands in the point of operation and a two hand control presence sensing device or Type B gate or movable barrier (on a part revolution clutch) is used for safeguarding:

- (i) The employer shall use a control system and a brake monitor which comply with paragraphs (b) (13) and (14) of this section.
- (e) Inspection, maintenance, and modification of presses-
 - (i) It shall be the responsibility of the employer to establish and follow a program of periodic and regular inspections of his power presses to insure that all their parts, auxiliary equipment, and safeguards are in a safe operating condition and adjustment. The

employer shall maintain records of these inspections and maintenance work performed.

1910.212

General requirements for all machines (covers press brakes, hydraulic and pneumatic machines not covered by mechanical power press standards)

- (a) Machine guarding - (1) Types of guarding. One or more methods or machine guarding shall be provided to protect the operator and other employees in the machine area from hazards such as those created by point of operation ingoing nip points, rotation parts, flying chips and sparks. Examples of guarding methods are: barrier guards, two-handed tripping devices, electronic safety devices, etc.

NOTE: These are only partial reprints, refer to your Federal Register for total construction, control reliability, and machine guarding requirements for the subject machine being guarded for all applicable OSHA Standards.

Appendix A:

Regulations & Guidelines for Safe Operation

PPG Series Safety Light Curtain

Machine Control Reliability Requirements

CONTROL RELIABILITY:

“...control circuits shall be designed and constructed so that a single failure or fault within the system does not prevent the normal stopping action from being applied to the press when required, or does not create an unintended stroking action, but does prevent initiation of a successive stroke until the failure is corrected.” (ANSI B11.1-1988)

“...control shall be designed to prevent initiation of a stroke signal in the event that a failure occurs within the press control.” (ANSI B11.2-1982)

“Robots shall be designed and constructed so that any single, reasonably foreseeable failure will not cause hazardous motion of the robot.” (ANSI/RIA R15.06-1991)

“...control circuits shall incorporate features to minimize the possibility of an unintended stroke in the event of the failure of the control component to function properly including relays, limit switches, and static output circuits.” (ANSI B11.1-1982)

“...control system shall be constructed so that a failure within the system does not prevent the normal stopping action from being applied to the press when required, but does prevent initiation of a successive stroke until the failure is corrected.” (ANSI B11.1-1982)

“...the control system shall be constructed so that a failure within the system does not prevent the normal stopping action from being applied to the press when required, but does prevent initiation of a successive stroke until the failure is corrected.” (OSHA CFR 1910.217, 1988)

Safety Guidelines for Management

Operational Safety

1. Appoint a Safety Coordinator to be responsible for safety regulations, requirements, and suggestions. He must review and investigate all accidents and “close calls.”
2. Establish and issue safety rules. Inform each employee of his responsibilities. Make sure he understands them and knows what is expected of him.
3. A thorough review and an early inspection must be made of existing presses, dies, and point of operation guarding to attain the degree of responsibility required by ANSI B11.1-1988 Safety Standards and Federal State laws.

Review what mandatory modifications are necessary.

4. Equipment that is no longer safe and that cannot be economically upgraded should be destroyed.
5. Never allow persons legally under age to operate or assist in the operation of machinery
6. All personnel must be properly trained to eliminate accidents and injuries.
7. Regardless of the operator's experience, education or language barrier, it is the responsibility of the supervisor to give him a thorough explanation with each new job assignment.
8. No employee should be given a work assignment that he does not fully understand. Only properly instructed and thoroughly trained personnel should be assigned to work on or with any machine.
9. It shall be the responsibility of the employer to provide an adequate, clean, safe and uncluttered work area around each machine.
10. If a malfunction is reported, stop the machine immediately, correct the problem, then resume production.
11. Investigate all accidents and close calls. Analyze the reason for occurrence. Take action to prevent recurrence. Keep records of the investigation and preventative steps that were taken.
12. Only employees who understand the machines, operation and safety requirements, and who are able to communicate this knowledge should be given the responsibility of instructing and training others to perform as operators.
13. Management must decide that personnel protective safety equipment is required to perform each job safely. Items such as safety glasses, shoes, gloves, helmets, hand pads, spats, protective sleeves, and material handling equipment are common in the metal working industry. If noise levels are excessive, protective head sets and ear muffs are recommended.
14. When designing point of operation guarding, the manufacturing process should be weighed heavily in favor of operational safety.
15. Establish safe and convenient material handling methods and procedures.
16. Post in convenient areas the names, addresses,

Appendix A:

Regulations & Guidelines for Safe Operation

PPG Series Safety Light Curtain

and phone numbers of physicians and hospitals, and members of the organization who are to be called in case of emergency.

17. All equipment must be electrically connected according to the National Electric Code and be consistent with other accepted practices.
18. Provide adequate and proper fire protection equipment.

Power Press Guarding

1. Press manufactures do not know and cannot foresee the magnitude of potential applications of power presses. Therefore, only the press user can determine the type of guards that have to be used in order to perform the job safely. It is the responsibility of the user management to make certain that point of operation guarding and other necessary safety devices are installed. The press should be guarded in such a manner that it is impossible for the operators to place their hands or any other part of the body in the die area.
2. The press user should become thoroughly acquainted with the safety devices commonly employed in power press operations.
3. Feeding devices are strongly recommended, since they remove the operator from the die area, and therefore allow more effective utilization of guards and safety devices.
4. Do not release a press for production before installing and testing all guards and covers.
5. Make frequent evaluation checks of all guarding and devices while the press is running. Correct all unsafe findings immediately.

Power Press Care Through Inspection and Maintenance

1. All maintenance and inspection personnel should be specifically instructed, and must understand proper maintenance and inspection procedures contained in this manual.
2. Set up a daily, weekly, and monthly press inspection program. Use a checklist and verify that the job is done correctly.
3. Establish a preventative maintenance program. Records of all maintenance work performed must be kept.
4. Since all equipment has a limited life, high quality

maintenance personnel are required to obtain maximum usage of your equipment.

5. Releasing a power press for production following maintenance should be the responsibility of a qualified individual assigned by management.
6. To maintain the original level of press reliability careful inspection of mechanical, electrical, and pneumatic areas must be made. This may give an advance warning of a hazard which then can be corrected to prevent possible injuries and damage.

Safety Enforcement

In order to have an effective safety program, management at all levels must enforce every safety rule and regulation. Strong disciplinary measures are sometimes required. They should consist of a warning, written reprimand, work suspension, transfer, demotion, or possibly a dismissal. All infractions must be reported and recorded. Once an infraction is noted, it shows that an unsafe practice or condition has existed. This may be the result of poor planning or improper training and instructing. The reason for the infraction should be analyzed in order to take corrective action.

Supervisor Training

It should be the responsibility of management to instruct their supervisors on safety, giving job instructions, supervising operators, determining accident causes, and building safety attitudes among the press operators. Many accidents have occurred due to a supervisors lack of training.

Operator Training

It shall be the responsibility of management to insure proper training of operators. A specific training program should be instituted to instruct the operator in safety, proper usage of the equipment, and correct operational procedure in performing each and every job. In addition to the supervisor, the operator should be familiar with the proper guarding of the point of operation. Never permit an operator to start a job without complete instructions from his immediate supervisor.

Appendix B:
Parts List
PPG Series Safety Light Curtain

Receiver Pylon

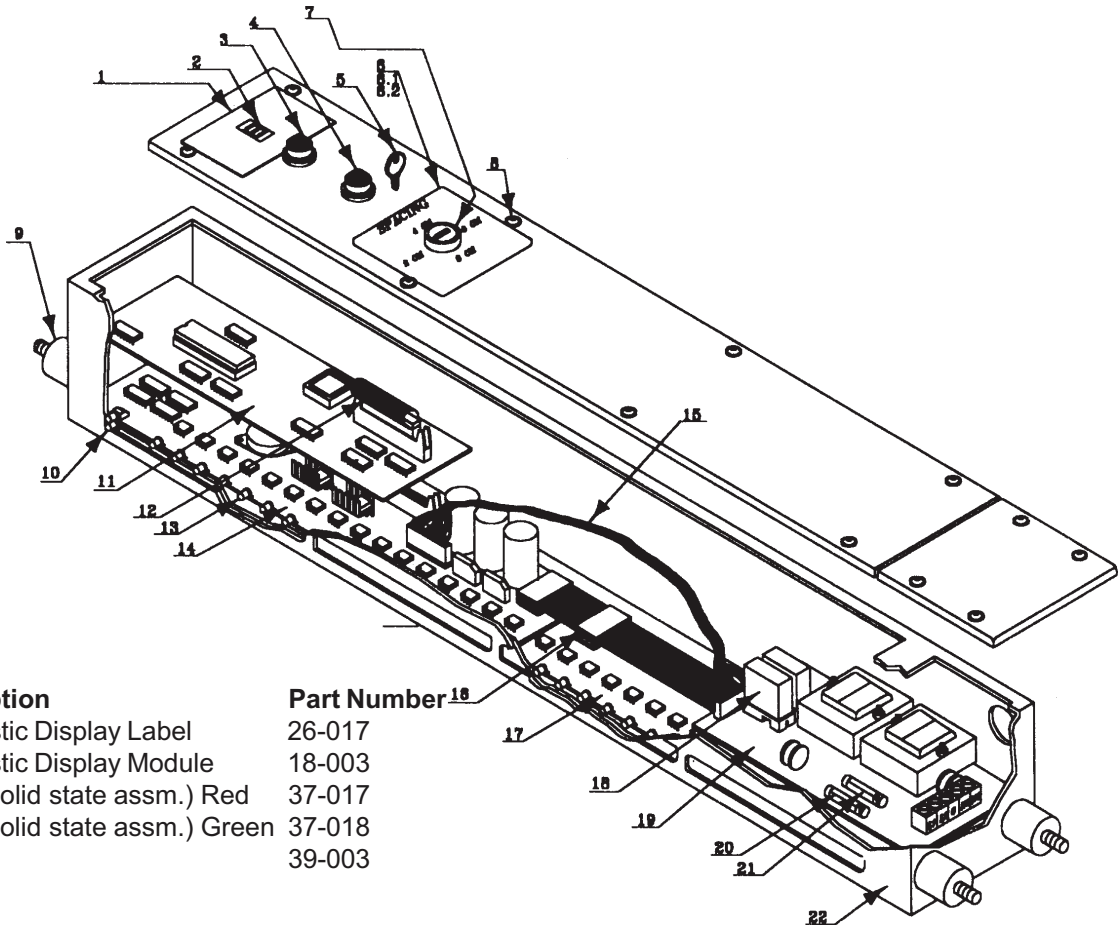

| Ref. # | Description | Part Number |
|--------|--------------------------------|--------------------------|
| 1 | Diagnostic Display Label | 26-017 |
| 2 | Diagnostic Display Module | 18-003 |
| 3 | Lamp (solid state assm.) Red | 37-017 |
| 4 | Lamp (solid state assm.) Green | 37-018 |
| 5 | Key | 39-003 |
| 6.2 | Warning Label | 26-023 |
| 8 | Cover Screw | 22-002 |
| 9 | Shock Mount | 21-019 |
| 10 | Sync LED(s) | 37-007 |
| 11 | Upper Receiver Bd. * ~ | 52-022 |
| 12 | Ribbon Cable (34cond.) | 52-083 |
| 13 | Phototransistor | 37-008 |
| 14 | Lower receiver Board * ~ | 52-023 |
| 15 | Power supply cable * | Call |
| 16 | Ribbon Cable (24cond.) * | Call |
| 17 | Slave receiver board * | 52-024 2CM 52-025 4CM |
| 18 | Relay ~ | 32-001 |
| 19 | Power supply board * ~ | 52-050 |
| 20 | Fuse (4A) | 20-003 |
| 21 | Fuse (1A) | 20-001 |
| 22 | Enclosure * ~ | Call |

* Model sensitive (Model number required)
~ Engineering level sensitive (Serial number required)

Appendix B:

Parts List

PPG Series Safety Light Curtain

Emitter Pylon

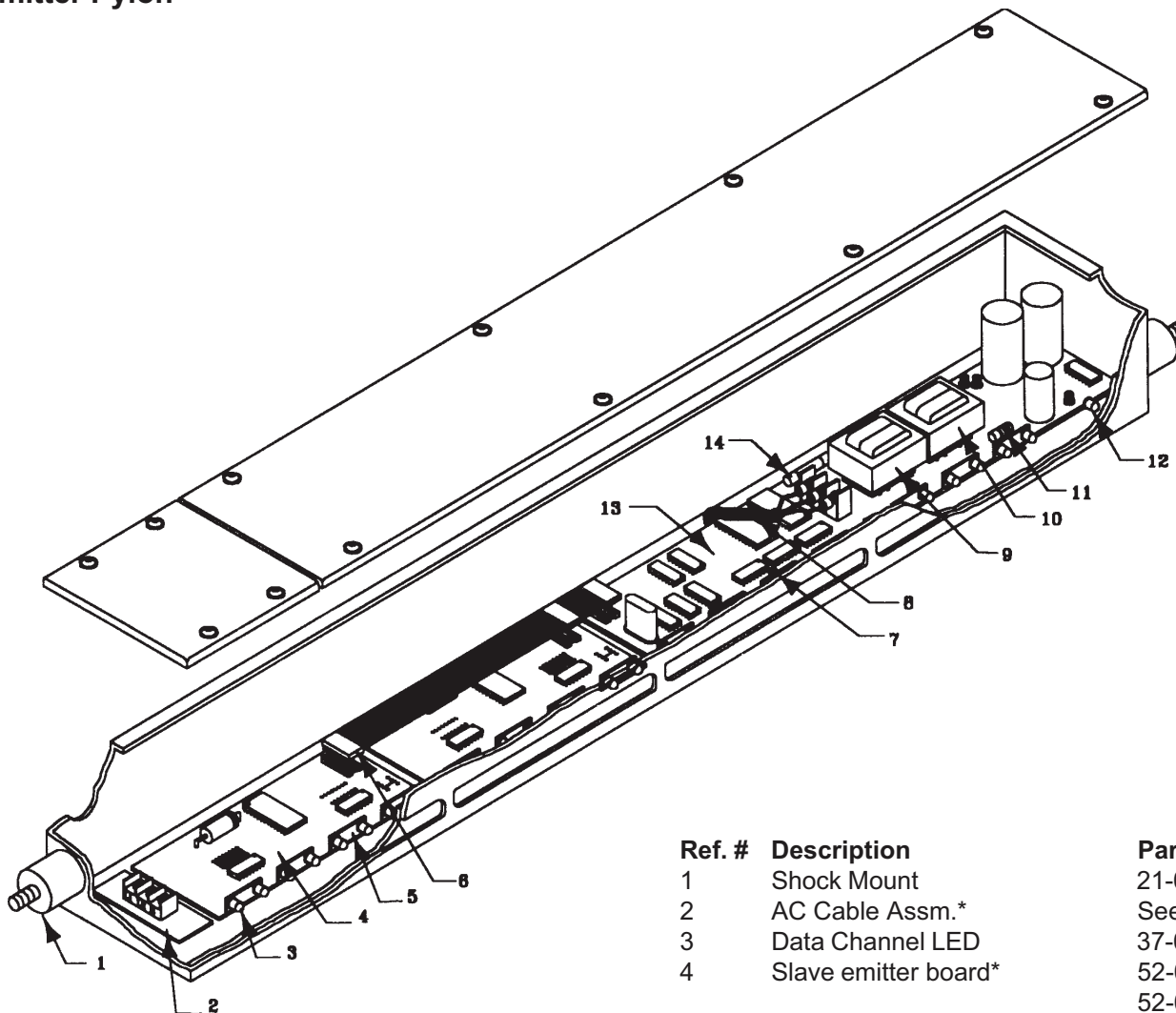

| Ref. # | Description | Part Number |
|--------|------------------------|-------------|
| 1 | Shock Mount | 21-019 |
| 2 | AC Cable Assm.* | See ref 8 |
| 3 | Data Channel LED | 37-007 |
| 4 | Slave emitter board* | 52-017 2CM |
| | | 52-018 4CM |
| 5 | Phonolic Mount | 21-016 |
| 6 | Ribbon Cable (16cond.) | Call |
| 7 | Sync light (ref. only) | |
| 8 | AC Cable Assm.* | Call |
| 9 | +/- 15V Xformer | 41-009 |
| 10 | + 10V Xformer | 41-007 |
| 11 | 2.4 ohm 1w resistor | 34-001 |
| 12 | Sync Phototransistor | 37-008 |
| 13 | Master trans. board | 52-015 |
| 14 | Fuse (1A) | 20-001 |

* Model Sensitive (Model number required)

WARRANTY

Manufacturer warrants that this product will be free from defects in material and workmanship for a period of two years from the date of shipment thereof. Within the warranty period, manufacturer will repair or replace such products which are returned to it with shipping charges prepaid and which will be disclosed as defective upon examination by the manufacturer. This warranty will not apply to any product which will have been subject to misuse, negligence, accident, restriction, and use not in accordance with manufacturer's instructions or which will have been altered or repaired by persons other than the authorized agent or employees of the manufacturer.

DISCLAIMER

The provisions of the paragraph "Warranty" are the sole obligations of the manufacturer and exclude all other warranties of merchant ability, expressed or implied.

Further, there are no warranties which extend beyond the above warranty

LIMITATION OF LIABILITY

In the event of any claim or breach of any obligations of manufacturer under any order, whether expressed or implied, and particularly in the event of any claim or a breach of the warranty or warranties contained in the paragraph "Warranty" or of any other warranties, expressed or implied which might, despite the paragraph entitled "Disclaimer," be determined to be incorporated in any order, the company shall under no circumstances be liable for any consequential or special damages, either in law or in equity, or for losses or expenses or claims for the same arising from the use of, or inability to use, the products of the manufacturer for any purpose whatsoever.

WARNING: The entire machine safety system must be tested at the start of every shift. Machine testing should include:
(1) proper machine operation and stopping capability; and
(2) verification of proper installation and settings of all point of operation guards and devices before the operation is released for production.



Sales and Marketing Offices

United States

Pinnacle Systems, Inc.
P.O. Box 100088
Pittsburgh, PA 15233

Toll Free Number: 800-569-7697

Direct Number: 412-262-3950

Fax: 412-262-4055

Canada

Pinnacle Systems, Inc.
8-1734 Orangebrook Court
Pickering, Ontario L1W 3G8

Toll Free Number: 888-285-8885

Direct Number: 905-831-1111

Fax: 905-831-4064

We have designed our equipment to the very highest performance and safety standards known to the current technological state of the art, as evidenced by our U.S.A. and foreign patents issued and pending. However, the installation, usage, suitability, and fitness of our equipment for any purpose, known or unknown, is interdependent upon the performance of other equipment not manufactured, installed, secured or maintained by Pinnacle Systems, Inc.

We cannot and do not accept responsibility for any overall system performance when factors, such as these, are beyond our control.

www.pinnaclesystems.com

sales@pinnaclesystems.com
service@pinnaclesystems.com