

# Model CE

## Safety Light Curtain

with Solid State Outputs and  
External Device Monitoring (EDM)



- Low Cost Solution for OEM's/Integrators
- Compact "Control Reliable" Category 4 Design
- The Easiest Intelligent Blanking Setup Available
- No Dip Switches or Pylon Entry Required for Blanking
- System Designed to Eliminate Time Consuming Lockout/Tagout Procedures for Blanking Adjustments
- Total System Diagnostics
- Made in USA

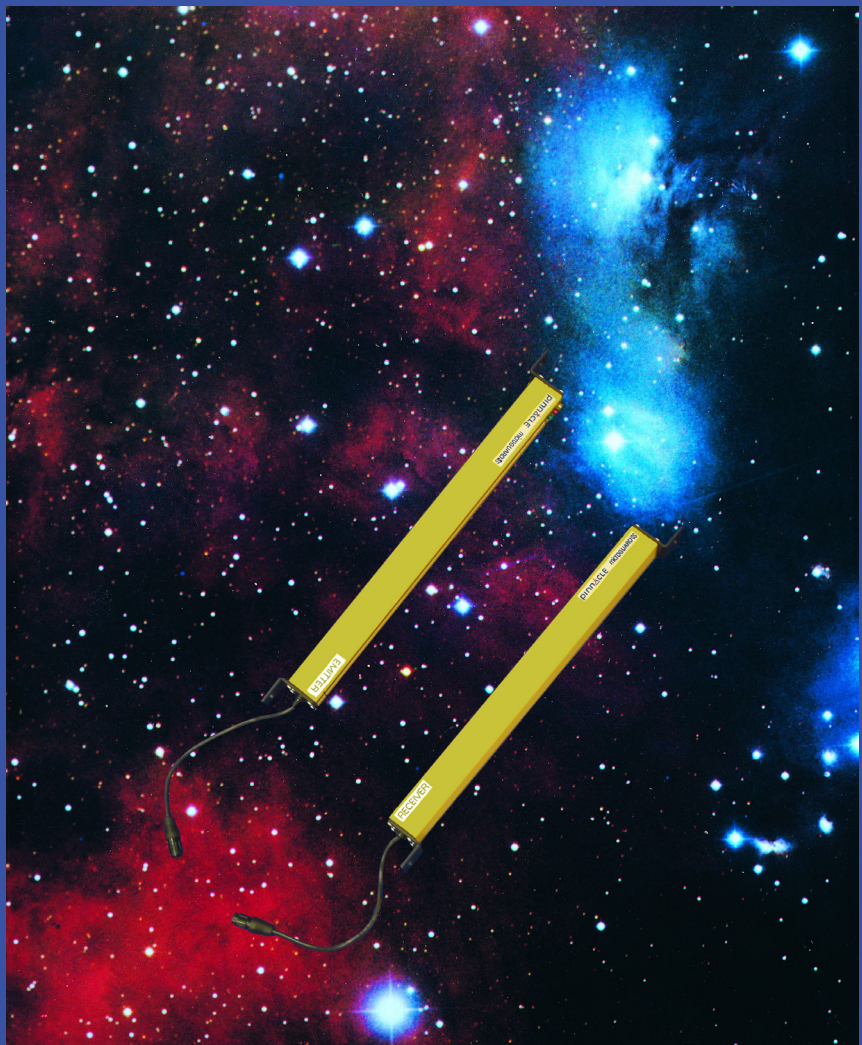

**PINNACLE**  
S Y S T E M S , I N C .

# The Ultimate in Safety – Quality – Value – Worldwide



The Model CE is an infrared safety light curtain that is designed to the IEC 61496 standard. When properly installed, it protects the machine operator by passing an invisible infrared light beam across an area to be guarded and examining whether or not the light beam(s) are blocked. If the light beam(s) are blocked, monitored solid state outputs will open, issuing a “STOP” command to the machines normally closed (N.C.) “STOP” circuit.

The System is composed of a transmitting unit (EMITTER), and a receiving unit (RECEIVER). The entire system is control reliable Category 4 (per IEC EN 954-1). A single fault anywhere within the Model CE will not prevent at least one of the solid state outputs from opening up, (allowing a “STOP” command) when either a beam is broken or an internal fault occurs.

**Theory of operation.** The Model CE protects an area by projecting a curtain of infrared light. The infrared emitters and receivers face each other across the field to be protected. Each emitter/receiver pair is spaced along the length of the pylons at regular intervals from .5” (13mm), up to 8” (203mm) depending on the application. The smaller spacing are for finger guarding, the larger spacing are for body protection.

The emitter/receiver pairs are scanned sequentially (one at a time) by a very short pulse of infrared light starting from bottom (cable end), and working up to the top, until every beam pair has been scanned. Two 16 bit computers in the emitter pylon and two 16 bit computers in the receiver pylon control the operation, as well as cross check each pylon.

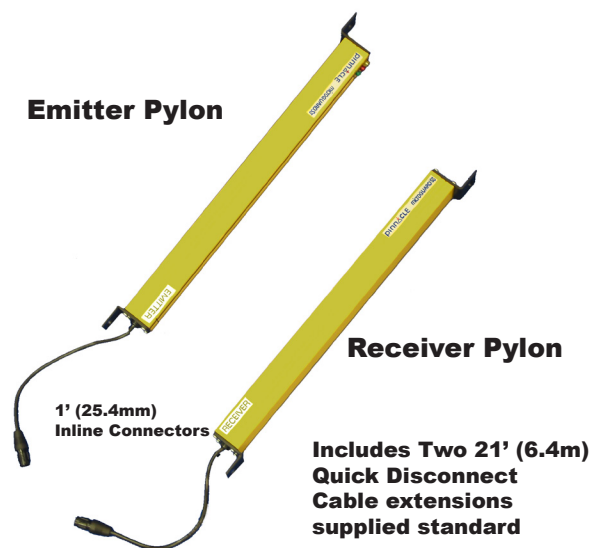

**The System.** The Model CE employs infrared technology in a small sealed NEMA 4 (IP65) aluminum housing with an infrared passing (daylight filtering) acrylic lens. This system provides harmless invisible protection and an unobstructed view of the guarded area. There are two parts to the Model CE: An Emitter pylon and a Receiver pylon. The Emitter pylon has no outputs, but does contain a digital CAN data network to allow it to be linked to the Receiver pylon (although not required for operation). The Receiver pylon contains the digital CAN data network and two monitored solid state 24vdc outputs.

Both pylons are synchronized to each other either via the CAN data network or electronically.

**External Device Monitoring (EDM).** A method in which the Model CE Category 4 safety light curtain logic monitors the state of various external control devices. The control devices are external and not part of the Model CE light curtain pylons. A lockout or stop signal will result if an unsafe state is detected in an external device.

The External Device Monitoring (EDM) is an optional function of the Model CE safety light curtain for monitoring the status of external devices such as gate and door switches, safety switches or the main control element of the drive (MPCE).

## Design Criteria:

- Designed to meet IEC 61496-1 & 2, UL 1998, UL subject 491, OSHA, ANSI, CSA, ANSI-RIA R15.06-1999
- Microprocessor redundancy for both Emitter and Receiver pylons
- Redundant, monitored, 24vdc solid state outputs (PNP)
- Watchdogs on CPU's and outputs prevent unintentional output during lockups.

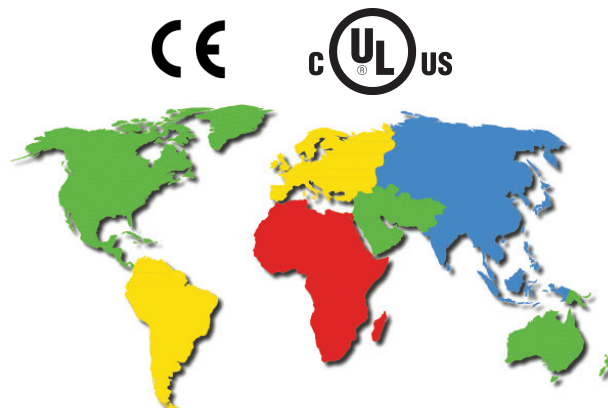

# Blanking Options

The optional **Remote Status Display (RSD)** may be used in conjunction with the Model CE Safety Light Curtain. The RSD provides the machine operator and front line supervisor immediate system status and diagnostics when the Model CE is mounted inside the machine control panel. The RSD also controls all blanking options directly from the panel location where it is installed.

## Remote Status Display (RSD) Components:

- Red/Green/Yellow indicator lights
- Diagnostic scrolling message display with 5' (1.5m) of connector cable
- Keyed selector switch and yellow blanking active indicator supplied if blanking is used

The RSD components are mounted on a steel plate and are designed to be exterior panel mounted. The RSD option enhances safety and is a time saver at machine set-up and when maintenance diagnostics are required.

## Cincinnati Interface

**Description:** The Cincinnati Interface is provided to allow an external device to determine if the light curtain is still capable of shutting down the safety control circuit. The Cincinnati Interface allows an external device to override the light curtain and initiate a RED condition and open up the standard output relay contacts.

**Application:** Cincinnati Press, PLC

- Manual Latching Relay Provision

## Floating Blank - (8K) Option

The “Floating Blank” option provides the flexibility necessary to effectively guard all types of equipment that require multiple floating beams. This is quite common in the fabricating industry where the work piece moves.

The “Floating Blank” permits work pieces to be formed vertically or horizontally through the guarded area without shutting down the machine. Entry into the protected area by the operator or passerby will prevent the start or, if the machine is in motion, will provide a signal to stop the machine.

The “Floating Blank” is controlled by a keyed selector switch that will allow a work opening of 2” (51mm) based on 1/2” (13mm) increments. This information is displayed on the message display of the controller. Blanking adjustments required when die heights change are not necessary. The “Floating Blank” light curtain automatically adjusts to the various feed positions providing **production with protection**.

The “Floating Blank” (8K) Option includes:

- |               |                               |
|---------------|-------------------------------|
| 1/2” (13mm)   | - Constant scan light curtain |
| 1” (25mm)     | - One floating beam           |
| 1 1/2” (38mm) | - Two floating beams          |
| 2” (51mm)     | - Three floating beams        |

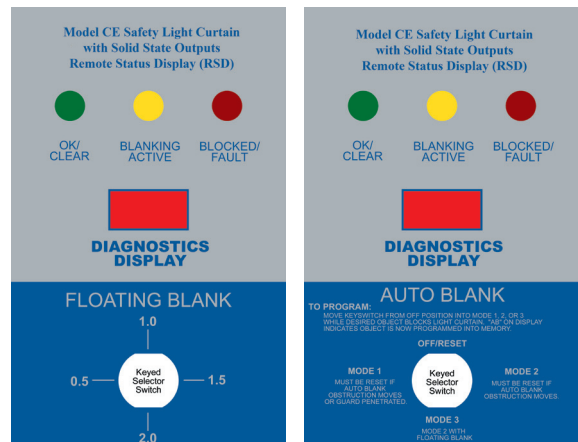

The (RSD) device provides blanking scrolling operator diagnostic message display and system status **without** entry into the machine control panel. This saves time for lockout/tagout requirements and safeguarding blanking adjustments.

## Auto-Blanking - (AB) Option

The advanced “Auto Blank” option is unique because it will automatically blank out only the required number of beams needed to accept an obstruction such as a conveyor, bracket, or fixture. The unit is easily programmed by a supervisory controlled four-position keyed selector switch located on the front panel of the RSD Display. The “Auto Blank” method of blanking is much safer than DIP switch or master/slave blanking systems because only the areas of the obstruction will be blanked. This feature prohibits unsafe oversizing of the blanked area commonly found throughout the industry on manually blanked systems. “Auto Blank” also **eliminates the need** to count beams and to locate where and what beams are to be shut off to obtain the correct beam elevation to accept an obstruction. This information is displayed on the message display of the controller. “Auto Blank” will also watch the obstruction and, if it moves or is removed, will go into a “machine stop mode” to prevent further machine operation. This is an additional safety feature not available on manually blanked units. These features truly enhance production while providing the ultimate in safety.

When the key switch is turned to the “Auto Blank” function, the “External Diagnostic Message Display” will show the number of blocked beams and where the obstruction is in the light curtain, then verify that the obstruction is being monitored. This is required information for the depth penetration factor and for proper installation of any safety light curtain.

The versatile “Auto Blank” (AB) blanking series includes:

- Constant scan light curtain
- One beam floating blank built-in plus “Auto Blank” capability
- Two “Auto Blank” modes - up to 8 beams blanked but need not be sequential
  - A. One “Auto Blank” mode with keyed reset when guarded zone is penetrated (latch)
  - B. One “Auto Blank” mode with automatic reset when guarded zone is penetrated

# Model CE

## A Size to Meet All of Your Guarding Needs

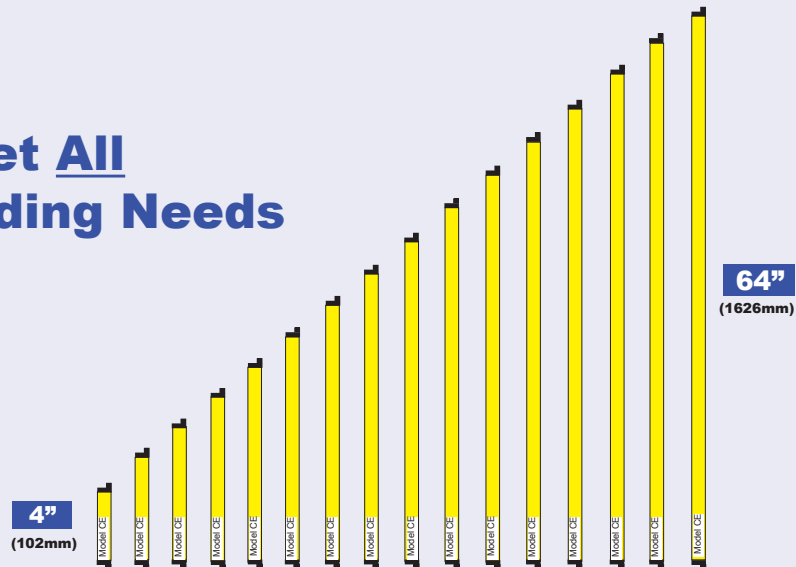

Swivel mounting brackets supplied with all pylons which provide 360° rotation for easy alignment and quick installation.

### Safety Relay and Socket Assembly - Part#: 52-278 (Two Required) Capable of DIN-Rail or Back Plate Mounting



Contact material	AgSn O <sub>2</sub> + 0.2µm Au
Type of contact	Crest contact
Rated switching capacity	250VAC 8A AC1 2'000VA
Electr. Life AC1 (360 cycles/h)	Approx. 100'00
Inrush current max.	20A for 20ms
Switching voltage range	5 to 250 VDC/VAC
Switching current range*	10mA to 8A
Switching capacity range*	0.06VA(W) to 2'000VA
Contact resistance (as delivered)	≤100m Ω/28V/100mA
*Guide values	

- Safety relay with force guided contacts (dry)
- Relay configuration: 2NO/1NC
- Mean coil power 0.75W
- Holding power 0.21W
- EN 50205 type A



- DIN rail socket
- Integrated retaining/ejector handles
- Screw terminals
- Assembly on DIN rail 35mm or with 2xM3 screws

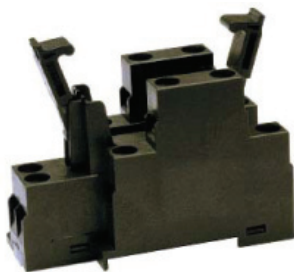

Technical data	
Rate current	6A
Rated voltage	250VAC
Test voltage coil/contacts	2'500Veff
Insulation class (IEC 60664-1)	250VAC
Creepage resistance	CTI 250
Weight	Approx. 65g
Ambient temperature	-25°C to +70°C
Cross sections for connection with	
-wires	2x2.5mm <sup>2</sup>
-end sleeves for strands	2x1.5mm <sup>2</sup>
Torque max.	0.8 Nm

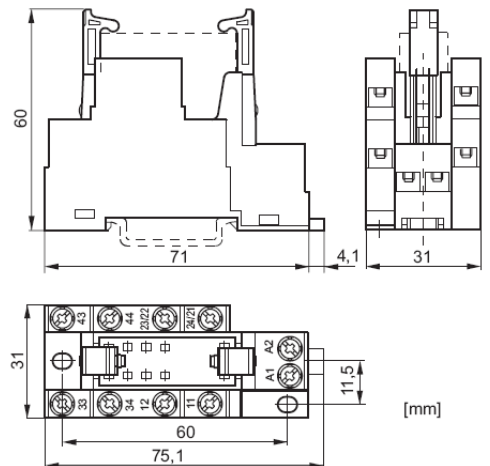

# Specifications and Dimensions

- **Input Power:**
  - Emitter pylon: 24vdc @ .125A
  - Receiver pylon: 24vdc @ .125A (solid state outputs are PNP which may draw up to .25A additional)
- **Internal fuses:**
  - Emitter Pylon: F1 @ 1A
  - Receiver Pylon: F1 @ 1A, F2 @ 1/2A, F3 @ 1/2A
- **Outputs:**
  - Receiver pylon: monitored, 2 outputs, solid state PNP (24vdc when GREEN, float when RED/off). Max .25A draw each.
- **Indicators:**
  - Emitter pylon: Yellow, Red, Green.
  - Receiver pylon: Yellow, Red, Green.
- **Construction:** Painted aluminum extrusion with Acrylic IR lens and Viton Seals providing NEMA 4 (IP65) protection. Cables are both 21' (6.4m) long with a flexible in-line connector 12" (254mm) from the base of each pylon (shielded). Maximum 100' (30.4m)
  - Emitter pylon: Four conductor 24AWG (Shielded)
  - Receiver pylon: Eight conductor 24AWG (Shielded)
  - Pylons: Yellow, with swivel mounting brackets
  - Cables: Black, shielded
- **Temperature:** 0 to 50c (up to 95% humidity, non-condensing)
- **Dimensions:** 1.45" (36.8mm) x 1.95" (49.5mm)
- **Beam Spacing & Minimum Object Sensitivity (MOS)**
  - .5" (12.7mm) .55" (14mm) MOS
  - 1" (25.4mm) 1.18" (30mm) MOS
  - (special order, 4" (102mm) active area followed by a 4" (102mm) gap)
  - (special order, 4" (102mm) active area followed by a 8" (204mm) gap)
- **Response Time and Scanning Frequency:** 30 mSec total, 10 khz
- **Shock:** Tested to withstand high vibration (using shock mounts)
- **Self-Checking:** Every 15mSec
- **Scanning distance**
  - From 1' to 20' standard (1-6m)
  - From 21' to 35' (6-10.7m) extended range (optional)
  - The range is stated as a two digit number within the Model #
- **Specials:** Custom designed light curtains for special applications. Consult factory.
- **Surface Mount Technology**
- **One Year Warranty**
- **Made in USA**

Model CE output circuits must be used with "control reliable" designed control systems.



## Pylons with Swivel Mounting Brackets

Model	DIM A (In/mm)	DIM B (In/mm)	DIM C (In/mm)	DIM D (In/mm)
CE-04	3.50 / 89	7.93 / 201	5.35 / 136	8.93 / 227
CE-08	7.50 / 190	11.93 / 303	9.35 / 238	12.93 / 328
CE-12	11.50 / 292	15.93 / 405	13.35 / 339	16.93 / 430
CE-16	15.50 / 394	19.93 / 506	17.35 / 441	20.93 / 532
CE-20	19.50 / 495	23.93 / 608	21.35 / 542	24.93 / 633
CE-24	23.50 / 597	27.93 / 709	25.35 / 644	28.93 / 735
CE-28	27.50 / 698	31.93 / 811	29.35 / 745	32.93 / 836
CE-32	31.50 / 800	35.93 / 913	33.35 / 847	36.93 / 938
CE-36	35.50 / 902	39.93 / 1014	37.35 / 949	40.93 / 1040
CE-40	39.50 / 1003	43.93 / 1116	41.35 / 1050	44.93 / 1141
CE-44	43.50 / 1105	47.93 / 1199	45.35 / 1152	48.93 / 1224
CE-48	47.50 / 1206	51.93 / 1319	49.35 / 1253	52.93 / 1344
CE-52	51.50 / 1308	55.93 / 1421	53.35 / 1355	56.93 / 1446
CE-56	55.50 / 1409	59.93 / 1522	57.35 / 1457	60.93 / 1548
CE-60	59.50 / 1511	63.93 / 1624	61.35 / 1558	64.93 / 1649
CE-64	63.50 / 1613	67.93 / 1725	65.35 / 1660	68.93 / 1751

(Incremental additives for longer pylons available)

- A. Guarded area (first to last beam)
  - B. Distance between mounting holes
  - C. Distance between mounting brackets
  - D. Total length (including brackets, but not cable)
- Tolerance: +/- .10"/2.5mm

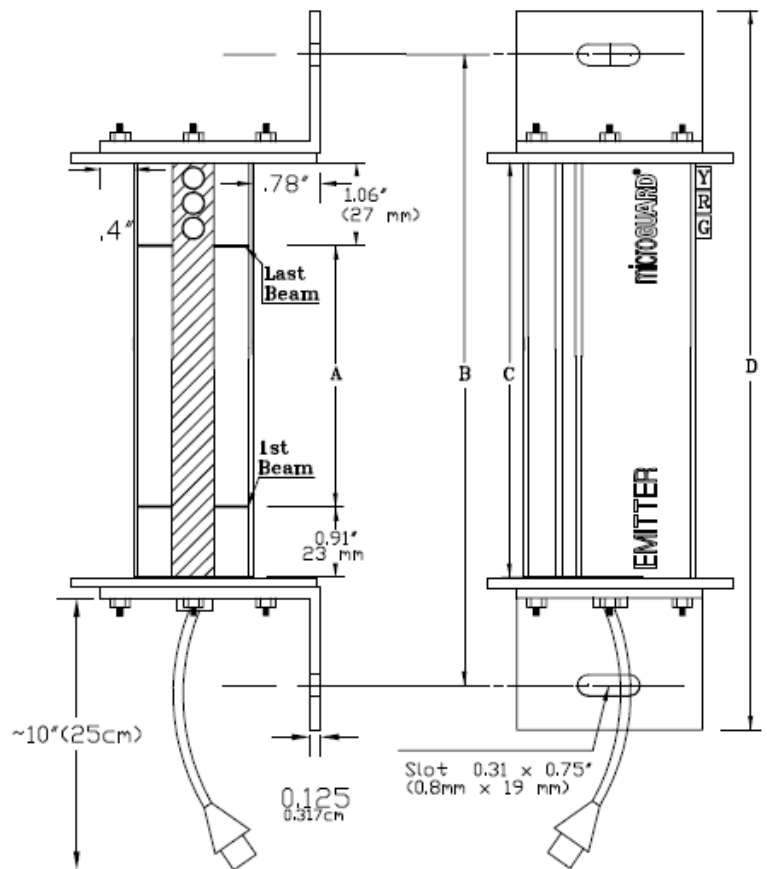

Pylon Dimensions: 1.45"(3.68cm) x 1.95" (4.95cm)

# Ordering Procedure

## Example Part #

<b>CE</b>	-	<b>04</b>	-	<b>OF</b>	-	<b>20</b>	-	<b>(Options)</b>
Solid State Outputs		Pylon Size		Light Curtain Style and Beam Spacing		Scanning distance in feet-20' (6.1m) standard, 35' (10.7m) maximum		Add suffix to part number

## Model CE Light Curtain Model or Style

CE - Solid State Outputs with External Device Monitoring (EDM) option

## Pylon Sizes (Protected Area in inches)

1/2" (13mm) Beam Spacing: 04,08,12,16,20,24,28,32,36,40,44,48,52,56,60,64

1" (25mm) Beam Spacing: 04,08,12,16,20,24,28,32,36,40,44,48,52,56,60,64

4" (102mm) Beam Spacing: 04,08,12,16,20,24,28,32,36,40,44,48,52,56,60,64

## Light Curtain Style and Beam Spacing

### 1/2" (13mm) Spacing of Beams

OF - Constant scan - no blanking.

1F - 1 beam floating blank built-in.

8K - Up to 3 beam floating blank adjustable by the use of a supervisory keyswitch removable in all positions. Capable of constant scan or one, two, or three floating beams. (Requires RSD option)

AB - Includes constant scan light curtain, one beam floating blank, and two auto blank modes. (Requires RSD option)

### 1" (25mm) Spacing of Beams

OF1 - Constant scan - no blanking.

1F1 - 1 beam floating blank built-in.

8K1 - Up to 3 beam floating blank adjustable by the use of a supervisory keyswitch removable in all positions. Capable of constant scan or one, two, or three floating beams. (Requires RSD option)

AB1 - Includes constant scan light curtain, one beam floating blank, and two auto blank modes. (Requires RSD option)

### 4" (102mm) Spacing of Beams (no blanking options available)

OF4 - For perimeter guarding, body detection. 4.25" (108mm) object sensitivity. 4" (102mm) active area followed by a 4" (102mm) gap.

## No Additional Charge Options (Add underlined suffix to part number)

### AVAILABLE ON THE MODEL CE

EDM - **External Device Monitoring (EDM):** Feature enabled

LR - **Resettable Latching Relays:** Requires the light curtain to be manually reset every time the sensing field is penetrated.

## Options (Add underlined suffix to part number)

### AVAILABLE ON THE MODEL CE

RSD - **Model CE Remote Status Display (RSD):** Remote mounting plate providing a single location to mount the following on existing panel door: light curtain scrolling diagnostic message display, blanking keyswitch (if applicable), and status indicator lights (all styles).

**Extended Range Units:** 21' (6.4m) to 35' (10.7m) scanning distances (specify desired scanning distance).

MPI - **Multiple Pylons (two sets)**

Connected via the CAN Network with one light curtain set area/zone share a common output

MP2 - **Multiple Pylons (three sets or more)**

Connected via the CAN Network with light curtain set two areas/zones with two outputs.

**Model CE Output Circuits must be used with "Control Reliable" designed control systems.**

# Accessories

## Cornering Mirror Dimensions

Through the use of cornering mirrors, multiple sides or work envelopes can be guarded which enhance safety and reduce downtime related to mechanical and electrical interlock systems. Include a 15% reflectivity loss per mirror when calculating the total scanning distance of the light curtain.

Model	Dim A (hole to hole)	Dim B (mirror)	Dim C (total)
MGM-12	19.45" (494mm)	18.25" (464mm)	20.50" (521mm)
MGM-18	25.45" (646mm)	24.25" (616mm)	26.50" (673mm)
MGM-24	31.45" (799mm)	30.25" (768mm)	32.50" (825mm)
MGM-30	37.45" (951mm)	35.25" (895mm)	38.50" (978mm)
MGM-36	43.45" (1104mm)	42.25" (1073mm)	44.50" (1130mm)
MGM-42	49.45" (1256mm)	48.25" (1226mm)	50.50" (1282mm)
MGM-48	55.45" (1408mm)	54.25" (1378mm)	56.50" (1435mm)
MGM-60	67.45" (1713mm)	66.25" (1683mm)	68.50" (1739mm)
MGM-72	79.45" (2018mm)	78.25" (1988mm)	80.50" (2045mm)
MGM-84	91.45" (2323mm)	90.25" (2292mm)	92.50" (2350mm)
MGM-96	103.45" (2628mm)	102.25" (2597mm)	104.50" (2654mm)

## Pedestal Dimensions (Model 8000)

The heavy duty, all welded steel pedestal floor mounts can be used for mounting either light curtain pylons or cornering mirrors. Sliding mounts on the pedestal are of universal design and are supplied standard. Unique floating base on pedestal is designed to compensate for uneven floors.

**NOTE: Pedestals must be bolted to the floor, they must not be movable (ANSI B11.19-2003).**

1. Sliding mounts supplied
2. Standard height is 72" (1829mm) - Model #8000  
Optional 96" (2438mm) - Model #8096
3. Painted OSHA yellow
4. Pedestal is 12 gauge steel  
Base Plate is 1/4" (6.35mm) steel plate

## Safety Light Curtains

*"A system designed specifically for your machine guarding needs"*



	Model MG – Metal Box	Model DR – DIN Rail	Model SS & CE – Solid State
<b>Description</b>	"Thin Profile" with Nema 12 (IP 64) Enclosure and two Quick Disconnect cables	"Thin Profile" with "Intelligent Safety Relay" DIN-rail Controller and 22' (6,705mm) Quick Disconnect cables	"Thin Profile" with Solid State Outputs and two 21' (6,096mm) Quick Disconnect cables with multi-directional pigtailed
<b>Controller Enclosure</b>	Metal Box	Gray Polycarbonate (IP 40) UL94 V-1	N/A
<b>Pylon Construction</b>	Aluminum Extrusion NEMA 4 (IP 65)	Aluminum Extrusion NEMA 4 (IP 65)	Aluminum Extrusion NEMA 4 (IP 65)
<b>Input Voltage</b>	120VAC, 24VDC, 220VAC	24VDC	24VDC
<b>Sizes</b>	4" (102mm) – 120" (3,048mm) in 4" (102 mm) increments	4" (102mm) – 120" (3,048mm) in 4" (102 mm) increments	4" (102mm) – 120" (3,048mm) in 4" (102 mm) increments
<b>Beam Spacing</b>	1/2" (13mm) or 1" (25mm) beam centers	1/2" (13mm) or 1" (25mm) beam centers	1/2" (13mm) or 1" (25mm) or 4" (102mm) beam centers
<b>Blanking Style</b>			
Auto Blank	Yes	Yes	Yes
Floating Blank	Yes	Yes	Yes
<b>Scanning Ranges</b>	1' – 50' (.3-16m)	1' – 50' (.3-16m)	1' – 50' (.3-16m)
<b>Warranty</b>	2 Years	2 Years	1 Year

Also Available!

# Extremely Durable Safety Mats Available in Any Shape or Size!

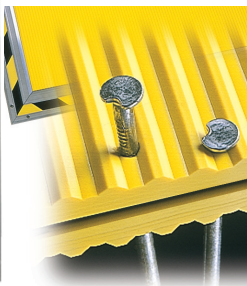
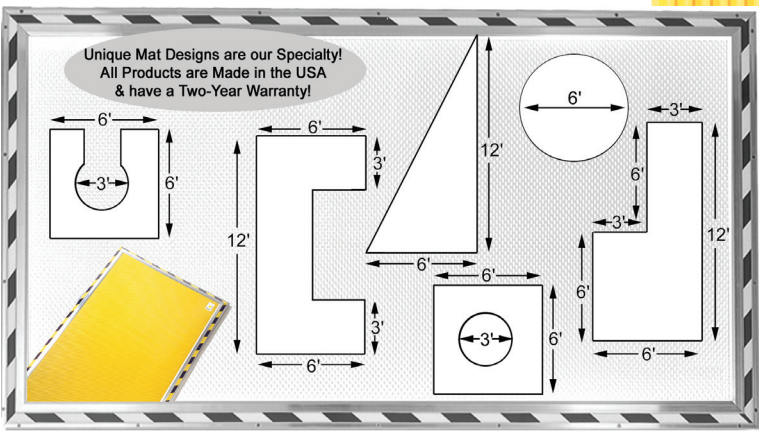

**Additional Products Available:**

- Safety Light Curtains
- Press Brake Controls
- Mute Out Packages
- Brake Performance Testers



For more information, visit  
[www.triadcontrols.com](http://www.triadcontrols.com)  
[sales@triadcontrols.com](mailto:sales@triadcontrols.com)



- Safety Light Curtains
- Safety Mat Systems
- Ergonomic Palm Buttons

For more information, visit  
[www.pinnaclesystems.com](http://www.pinnaclesystems.com)  
[sales@pinnaclesystems.com](mailto:sales@pinnaclesystems.com)

- Resolver Based Clutch/ Brake Controls
- Rotary Cam Based Clutch/ Brake Controls
- Punch Press Automation Controllers
- Time Based Brake Monitor



For more information, visit  
[www.pressroomelectronics.com](http://www.pressroomelectronics.com)  
[sales@pressroomelectronics.com](mailto:sales@pressroomelectronics.com)

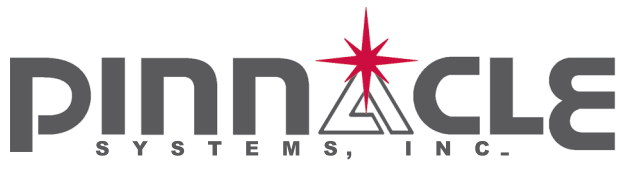

P.O. Box 9305  
Pittsburgh, PA 15225

Place  
Postage  
Here

Visit us on the web at [www.pinnaclesystems.com](http://www.pinnaclesystems.com)  
[sales@pinnaclesystems.com](mailto:sales@pinnaclesystems.com) | [service@pinnaclesystems.com](mailto:service@pinnaclesystems.com)