

# microGUARD®

Advanced control technology  
thin profile safety light curtain



- User friendly
- Continual system status checks
- Easily viewed message display
- Fits tight spaces
- Highly reliable solid state performance
- Meets OSHA, UL, ANSI, CSA, RIA, and CE standards
- DeviceNet™ capable
- Designed to meet international standards
- DIN-rail and Metal Box Controllers available

3rd Party  
Certifications



**PINNACLE**  
S Y S T E M S , I N C .

# microGUARD®

## The Thin Profile Light Curtain With A Smart Controller

**More safety features — fits in tight spaces — continual message display communicates system status — high reliability — meets OSHA, ANSI, CSA, RIA, and CE standards.**

**Introducing MicroGuard**, the revolutionary new light curtain. MicroGuard is thin in design, fits into tight spaces, uses reliable infrared technology, solid state construction, is easy to install and continually **visually communicates the system status** with operators and plant personnel.

**The MicroGuard advantage** is the **advanced smart controller design** that allows the operator and plant personnel to perform **immediate visual** checks on the system status. There are **50 diagnostic messages** which provide an exact determination of the MicroGuard's operational status on a continual basis. **Messages are easily viewed** from the message display on the front of the controller. The operator can verify the condition of operation and status of the system at all times.

For the first time, the MicroGuard's design allows a **quick and easy resolution to system faults and maintenance concerns**. Constant communication between the operator and the MicroGuard will save valuable operating time by reducing machine down time. The self-diagnostic capability allows the MicroGuard to trouble-shoot itself by identifying system faults. This constant operating evaluation allows problems to be immediately corrected. This ensures that each MicroGuard user will get maximum machine utilization.

MicroGuard is **user friendly**. Simple cable hook-ups are used to activate the MicroGuard. Power is common 120VAC, 220VAC, or 24VDC. The thin profile is easily mounted in tight spaces and is available in 30 sizes that can be adapted to any application need. The thin profile pylons feature 1/2" (13mm) or 1" (25mm) beam spacing with an easy alignment feature.

Solid state modular NEMAIV (IP65) construction is easy to maintain with snap-in circuit board construction. Lens covers are high impact plastic and are easily replaced. The redundant circuit and microprocessor design of the MicroGuard ensures safe, uninterrupted operation.

The MicroGuard is also designed for immunity to noise, light, weld flash, and other ambient light sources and is available in either a metal box enclosure or a compact 35mm DIN-rail mountable enclosure.





## Big on Safety/Small in Size

### Diverse Redundancy Design Concept

The MicroGuard safety light curtain utilizes the diverse redundancy design concept. This gives the safety light system a higher level of redundancy and control reliability. The two microprocessors are of different design, and the microprocessor or parallel programs are run and made up from different instruction sets written by different programmers.

### Self-Checking Circuitry

The MicroGuard safety light curtain self-checks every 20 milliseconds. Self-checking is the ability to electronically verify that all of the systems' critical internal circuit components and their redundant counterparts or back-ups are operating properly.

### Extra Safe Design

Provides two methods of cross monitoring design. One utilizes two microprocessors and two captive contact relays and the other uses four watchdog timers monitoring the system and the captive contact relays.

### Redundant Captive Contact Safety Relays

Redundant relays assure safety if an output relay should fail. The MicroGuard utilizes safety relays which have force-guided contacts. This is a configuration where the contacts are mechanically locked together so that if one set of contacts weld, the other contacts cannot change state. If one should fail, code "Relay Fault" will be displayed on the diagnostic message display. The complete guarding system consists of two miniature pylons with a controller for system diagnostics and wiring interface.

### External Diagnostic Message Display

Standard on all MicroGuard safety light curtains is the "External Diagnostic Display."

### Alphanumeric Plain English Messages

Scrolling message display shows status and fault codes of the unit. This is an excellent safety and maintenance feature which is unparalleled in the machine guarding industry for enhancing machine utilization.

### Control Reliable System

Critical components of the MicroGuard are duplicated so that a single component failure will not cause an unsafe condition. If a component does fail, the units' self-checking circuitry recognizes the situation and initiates a safe stop of the machine. The fault is then displayed on the message display.

### Powerful Infrared Light Source

The MicroGuard safety light curtain utilizes powerful, safe, and predictable infrared light as its sensing source. This gives the system greater reliability and enhances machine utilization by minimizing nuisance trips and shutdowns caused by dirt, coolants, lubrication mists, and machine oils. The MicroGuard is highly immune to EMI, RFI, and ambient light conditions and are unaffected by strobe lights and weld flash generated light sources.

### Extensive Testing

The MicroGuard safety light curtain incorporates extensive testing and burn-in to establish a high degree of product reliability and safety.

## MicroGuard Controller Unique Features

- Same controller for all size light curtains: 4" (102mm) to 120" (3048mm)
- Same controller for various input ranges: 24VDC, 120VAC, 220VAC
- Message display (external) - Bright red LED alphanumeric scrolling message display
- 50 plain English diagnostic and operating status messages
- Counts and displays location of obstructed beams
- Counts and displays number of obstructed beams
- System diagnostics with display to aid in-field maintenance
- Blanking functions controlled by keyed selector switch on front panel with display and indicator
- Smart controller eliminates cumbersome troubleshooting techniques
- Control reliable system
- Internal mute-out system (optional)

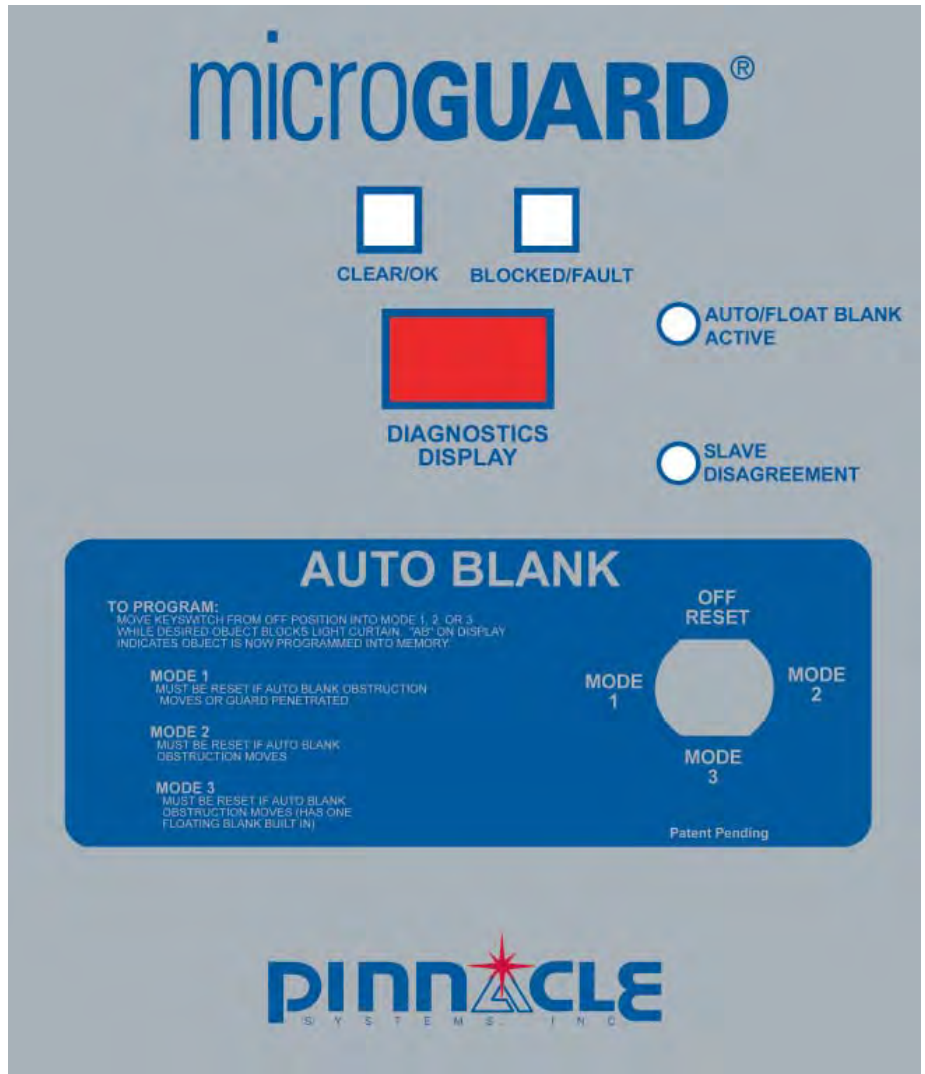

## MicroGuard Smart Controller

### With the “Quickview Diagnostic Message Display”

The Smart MicroGuard Controller makes machine guarding safer, easier to use, and enhances machine utilization measurably. It is unique in the machine guarding industry for the ability to constantly display the operating conditions of the safety light curtain. The Controller informs the user of any faults, failures, and the current operating status of the safety system in plain English on the external message display center. The message display is located on the front panel of the Controller (shown left). This gives the machine operator and front line supervisor access to information quickly and safely.

### Sample Display Messages

RECEIVER  
LENGTH FAULT

RELAY FAULT  
NOT ALL ON

RDY

EXT. RELAY  
CONTACT WELDED

The MicroGuard Controller diagnostics message display will show all faults related to redundant circuitry, microprocessors, captive contact safety relays, bad grounds, external infrared sources, shorts, blanking functions, etc. The Controller will also display the locations of misaligned or obstructed beams and then count and display how many beams have been obstructed. Additionally, if a printed circuit board or component should fail, the faulty board and beam number will be shown on the display. The board then can be replaced quickly in the field, eliminating costly downtime.

The counting and displaying the number of beams blanked out is required information when determining the depth penetration factor for proper installation of any light curtain.  
ANSI B11.19-2003.

### Output Circuitry

#### Safety Output Configuration

Every MicroGuard comes standard with two Captive Contact Safety Relays, auxiliary relay, and fault relay. The metal box controller can be configured for a “Single Stop” circuit or a “Dual Stop” circuit output.

**Single Stop Circuit SS** - Both internal Safety Relays are wired in series and the user is provided with one dry contact output. (Open when fault or blocked.) Supplied standard on the Metal Box (MG) Controller.

**Dual Stop Circuit DS** - Each internal Safety Relay is wired separately which provides the end-user with two separate dry contact outputs. (Both open when fault or blocked.) Add suffix DS to Metal Box (MG) part number.

The DIN-rail controller comes configured for a Dual Stop circuit with a jumper wire between outputs so that the user can wire into a Single Stop circuit system provided they wire both Safety Relays in series.

**WARNING** - Both safety relays in the dual stop configuration must be wired into the machine isolated stop circuits of the machine control.

Metal Box Controller Module Standard Provisions—designed to facilitate any guarding system interface and monitoring desired. Usage is optional.

#### CINCINNATI INTERFACE-with Red LED Indicator or EMERGENCY STOP INPUT (optional)

**DESCRIPTION:** The Cincinnati Interface is provided to allow an external device to determine if the light curtain is still capable of shutting down the safety control circuit. The Cincinnati Interface allows an external device to override the light curtain and initiate a RED condition and open up the standard output relay contacts.

**APPLICATION:** Cincinnati Press, PLC

#### EXTERNAL RELAY CHECK-with Green LED Indicator

**DESCRIPTION:** The External Relay Check allows the MicroGuard to monitor a pair of external relays in series using the external relays secondary set of DRY contacts, provided that they are N.C. force-guided contacts. The captive or force-guided contacts will maintain the identical positions as the primary set of contacts on the external relays, except that the secondary set of contacts are wired to signal the reverse of the primary (i.e., primary are N.O. and secondary are N.C.). The circuit looks for both closing and opening of the external relay contacts. The MicroGuard system is a safe external relay check.

**APPLICATION:** Monitoring external relay contacts for shorts or opens.

#### EXTERNAL VOLTAGE CHECK PROVISION-with Green LED indicator

**DESCRIPTION:** The External Voltage Check allows for the MicroGuard to monitor voltage coming from any outside source as a condition for keeping the light curtain green. This option is very similar to the External Relay Check except that this operates with high voltage so that it can be used to monitor other devices besides relay contacts.

**APPLICATION:** Monitor voltage at a solenoid, relay, etc.

#### AUXILIARY OUTPUT CONTACT PROVISIONS

**DESCRIPTION:** The Auxiliary Output Contact provides both an N.O. and N.C. isolated (DRY) contact output to signal the condition of the light curtain. The output is used in conjunction with the standard pair of output relays that are wired to the safety circuit of the equipment.

**APPLICATION:** Signal to PLC, etc.

#### DATA INPUT/OUTPUT FOR USE WITH REMOTE PLC (optional)

**DESCRIPTION:** This option allows the user to specify up to four signal lines as either input and/or output lines for issuing remote commands to the MicroGuard and/or sending commands to a PLC.

**APPLICATION:** Use this option if you need to know object size or to use your PLC to program Auto-Blank, Floating-Blank, reset “Penetration,” adjust guarded area, etc. This option is programmed at the factory for the user and is individually customized.

## Standard Features and Capabilities

### Metal Box Controller Module

- Meets or exceeds OSHA, ANSI, CSA, RIA, CE standards, UL Subject 491, UL1998, IEC 61496 standard parts 1 and 2
- Total system diagnostics and display for component and board level assemblies
- Two sets of operator status indicators
- Modular design for easy in-field maintenance
- Self-checking circuitry
- Fault relay output built-in
- Lockable controller box - NEMA 12 & 13 (IP 64)
- Easy access for wiring
- Push button reset with memory
- High immunity to strobe type and weld flash generated light
- Miniature design
- Extended scanning ranges available
- Replaceable infrared lens cover on pylons
- High immunity to EMI and RFI noise sources
- Interfaces easily with all types of machine controllers and PLC's
- Dual independent channel microprocessor design
- Single/multiple floating beam blanking with indicator
- Single/multiple fixed beam blanking with indicator
- Auto blanking feature with indicator
- Built-in machine interface monitoring
- Dual self-checking captive contact safety relays
- Non-mated units, matched sets are not required
- 2-, 3-, 4-, or 5-sided protection available with mirrors
- 30 standard sizes available: 4" (102mm) to 120" (3048mm) lengths in 4" (102mm) increments
- Easy to align and install
- In-field maintenance
- Multi-lingual diagnostic display available
- Two-year warranty
- Single controller for multiple light curtains (up to four sets)
- Made in the USA



### DeviceNet™

Complete system monitoring on DeviceNet fieldbus networks. The MicroGuard controller family is fully compatible with the DeviceNet fieldbus and can be connected directly into the fieldbus for non-safety monitoring of system status. DeviceNet is the leading low-cost communications link that connects a wide range of automated manufacturing devices for greater usability and convenience. Multiple MicroGuard controllers can be networked with numerous other devices on a single DeviceNet network. Add suffix DN to controller part number for this optional feature.



## DIN-rail Mountable Controller Module



- Meets or exceeds OSHA, ANSI, CSA, RIA, CE standards, UL Subject 491, UL1998, IEC 61496 standard parts 1 and 2
- Snap-out wiring terminals reduce both installation and maintenance time
- Universal controller for all pylon sizes
- Small and compact DIN-rail Mountable Controller
- Small and compact light curtain pylons
- Multiple status indicators for operator awareness
- Quick disconnect wiring at pylons
- Largest selection of sizes available
- Largest selection of options available
- Multi-lingual diagnostic display available
- Diverse redundant design concept
- Utilizes captive contact force-guided safety relays
- Largest selection of blanking options available—fixed or floating blanking
- Patented “auto blank” capable controller
- Remote status display (RSD) capable
- Diagnostic message display built-in
- External relay checking built-in
- Emergency stop input built-in
- Auxiliary relay output built-in
- Fault relay output built-in
- Remote latching reset built-in
- Remote indicator lights output provision built-in
- Push button reset with memory
- Analog output for non-safety related applications (optional) -10v to +10v or 0 to +10v (consult factory)
- Two-year warranty
- Made in the USA

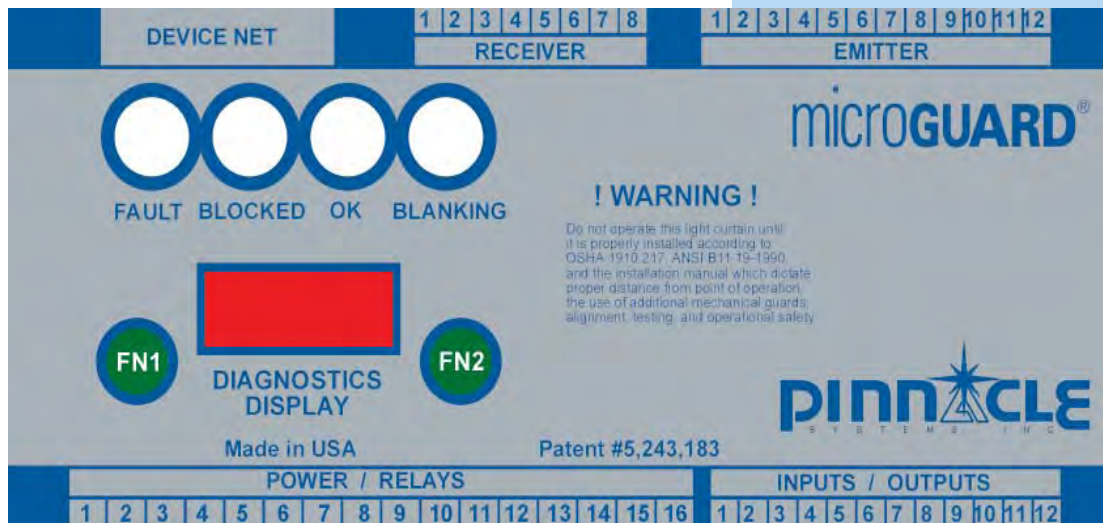

(Actual Size)

# DIN-rail Remote Status Display (RSD)<sup>TM</sup>

The optional Remote Status Display (RSD) may be used in conjunction with the MicroGuard DIN-rail Controller. The RSD provides the machine operator and front line supervisor immediate system status and diagnostics when the DIN-rail Controller is mounted inside the machine control panel. The RSD can also control all blanking options if that style light curtain is used.

### Remote Status Display (RSD) Components:

- Red/Green/Yellow indicator lights
- Diagnostic scrolling message display with 5' (1.5m) of connector cable
- Keyed selector switch and yellow blanking active indicator supplied if blanking is used

The RSD components are mounted on a steel plate and are designed to be exterior panel mounted. The RSD option enhances safety and is a time saver at machine set-up and when maintenance diagnostics are required.

(The RSD's shown are actual size)

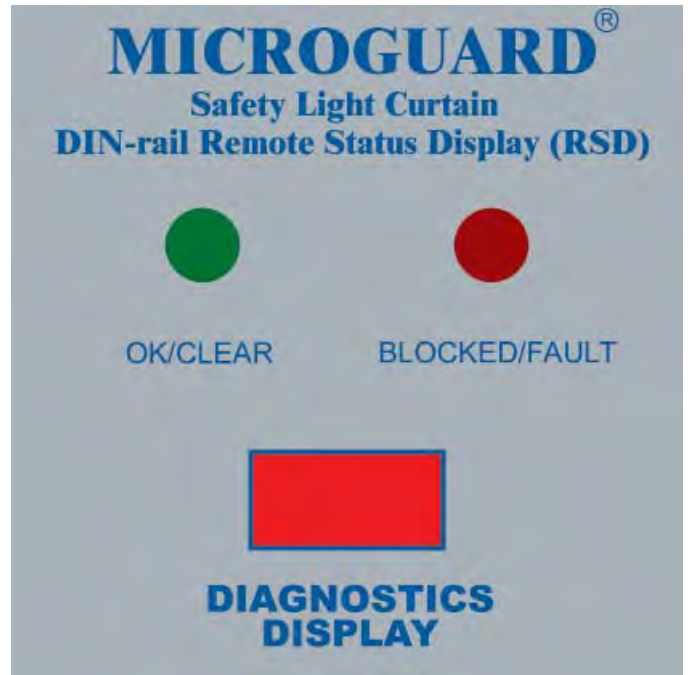

Requires 3" (76mm) x 3" (76mm) Panel Cutout  
 Mounting Hole Dimensions 3.7" (94mm) x 3.7" (94mm) Center to Center

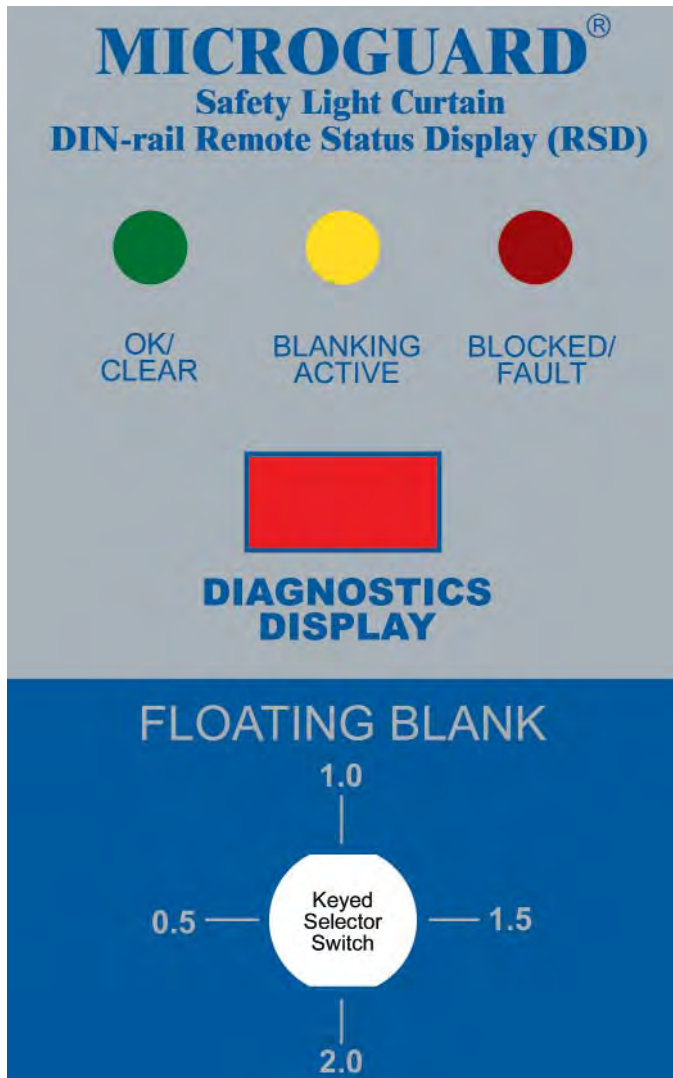

Requires 3" (76mm) x 5.10" (130mm) Panel Cutout — Mounting Hole Dimensions 3.7" (94mm) x 5.8" (147mm) Center to Center

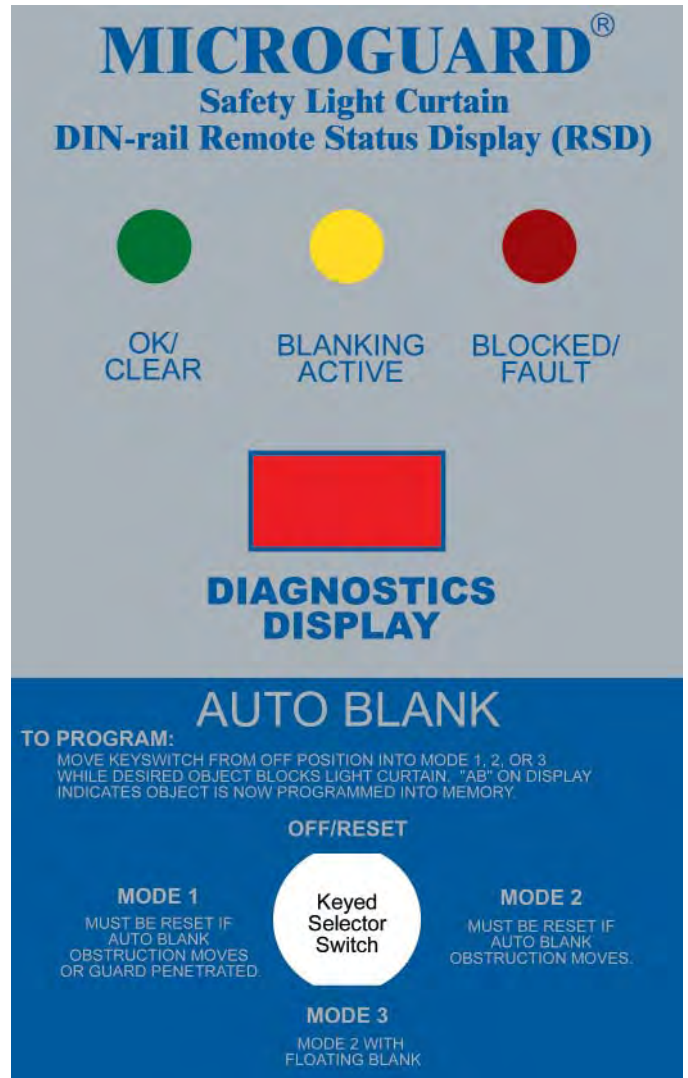

# microGUARD®

## Standard System Features for Metal Box and DIN-rail Controllers

- Pylons:**
  - Heavy duty aluminum extrusion NEMA IV (IP 65)
  - Replaceable infrared lens cover (acrylic)
  - Sealed bulkhead positive locking circular connectors
  - Mounting brackets supplied standard
  - Emitter pylon - red/green/yellow status indicators
- Cables:**
  - Shielded PVC 22 AWG cables with quick disconnects and strain relief fittings
  - Emitter cable - 20' (6.1m) supplied standard for the Metal Box Controller Module and 22' (6.7m) supplied standard for the DIN-rail Controller Module
  - Receiver cable - 8' (2.44m) supplied standard for the Metal Box Controller Module and 22' (6.7m) supplied standard for the DIN-rail Controller Module
- **External Alphanumeric Diagnostic & Status Message Display**
- **Infrared Light Source:** Solid state light emitting diodes
- **Beam Spacing:** 1/2" (13mm) or 1" (25mm)
- **Minimum Object Sensitivity:**
  - 1/2" (13mm) beam spacing is .55" (14mm)
  - 1" (25mm) beam spacing is 1.18" (30mm)
- **Response Time:** < 30 milliseconds (all sizes)
- **Scanning Frequency:** 5.9 KHz
- **Temperature Range:** 32° to 120° F (0° -51° C)
- **Shock tested** to withstand high vibration applications per UL991
- **Self-Checking** every 20 milliseconds
- **Scanning Distance:** All units are supplied standard with a 20' (6.1m) scanning capability. Extended range units are available, consult your representative or the factory. Scanning distances must be specified—50' (15.24m) maximum.
- **Complete Guarding System Supplied:** Transmitter and receiver pylons, controller, mounting brackets, connectors and cables, installation and operation manual.
- **CSA Approved, UL Listed, and CE Certified**
- **Two-Year Warranty**
- **Patented #5,243,183**
- **Category 4 Safety Device per EN954**
- **DeviceNet™ Fieldbus Network Compatible (optional)**

## Specifications

### Metal Box Controller Module

- **Input Power:** 18 to 35VDC @ 10W  
90 to 140VAC @ 12VA Standard  
140 to 220VAC @ 12VA  
All AC voltages work with 50 or 60 Hz
- **Power Consumption:** 11 watts total
- **Output Circuit:** Two captive contact self-checking safety relays
- **Relay Contact Rating:** Rated at 8 AMPS @ 250VAC resistive
- **Auxiliary Output Contact:** Rated at 8 AMPS @ 250VAC resistive
- **Fuses:** AC power: 1 AMP SLOW BLOW  
DC power: 1 AMP FAST BLOW  
External Voltage Check: 5 AMP FAST BLOW
- **Fault Output Relay:** Isolated output for faults
- **Metal Box Indicators:**

<b>External:</b>	OK/CLEAR	Green LED
	BLOCK/FAULT	Red LED
	AUTO/FLOAT ACTIVE	Yellow LED
	SLAVE DISAGREEMENT	Red LED
	DIAGNOSTICS DISPLAY	Alphanumeric scrolling message display
<b>Internal:</b>	+ 12V	Red LED
	Cincinnati Interface	Red LED
	+ 5V	Yellow LED
	External Relay	Green LED
	+ 5V	Yellow LED
	External Voltage	Green LED
	- 5V	Green LED
- **Diagnostic Message Display:** English or Spanish available. Customized languages are also available, consult factory.
- **Push Button Reset with Memory**
- **Enclosure:** All 18 gauge painted steel NEMA 12 (IP 64) lockable box with sealed front panel and sealed cable entry fittings (8 lbs.)

### DIN-rail Controller Module

- **Input Power:** 24VDC +/- 20%
- **Power Consumption:** 7 watts maximum
- **Output Circuit:** Two captive contact self-checking safety relays
- **Relay Contact Rating:** Rated at 8 AMPS @ 250VAC resistive  
Rated at 8 AMPS @ 120VAC resistive
- **Auxiliary Output Contact:** 5AMP @250VAC resistive
- **Input Fuse:** 1 AMP FAST BLOW (pico size)
- **Fault Output Relay:** 5AMP @250VAC resistive
- **DIN-rail Controller Indicators**

<b>External:</b>	CLEAR/OK	Green LED
	BLOCK/FAULT	Red LED
	BLANKING ACTIVE	Yellow LED
	BLOCKED	Red LED
<b>Internal:</b>	+ 5V	Yellow LED's (2)
	Relays	Green LED's (4)
	+ 12V	Red LED (1)
	- 5V	Green LED (1)
- **Emergency Stop Input Built-In**
- **Diagnostic Message Display:** English or Spanish available. Customized languages are also available, consult factory.
- **Push Button Reset with Memory**
- **Enclosure:** Gray polycarbonate with clear cover. Provides IP40, UL94V-1
- **Enclosure Dimensions:** 5.87" (149mm) length x 4.33" (110mm) depth x 2.95" (75mm) height
- **Enclosure Mounting:** 35mm DIN-rail mountable  
or  
Mounting screws on corners of enclosure requiring two combo-head screws (3.5 x 0.6mm x 14mm or #6 x .5)



# Blanking Options for Metal Box & DIN-rail Controllers

The Most Complete Format of Blanking Options Available in Industry

Select the Style Best Suited for Your Application

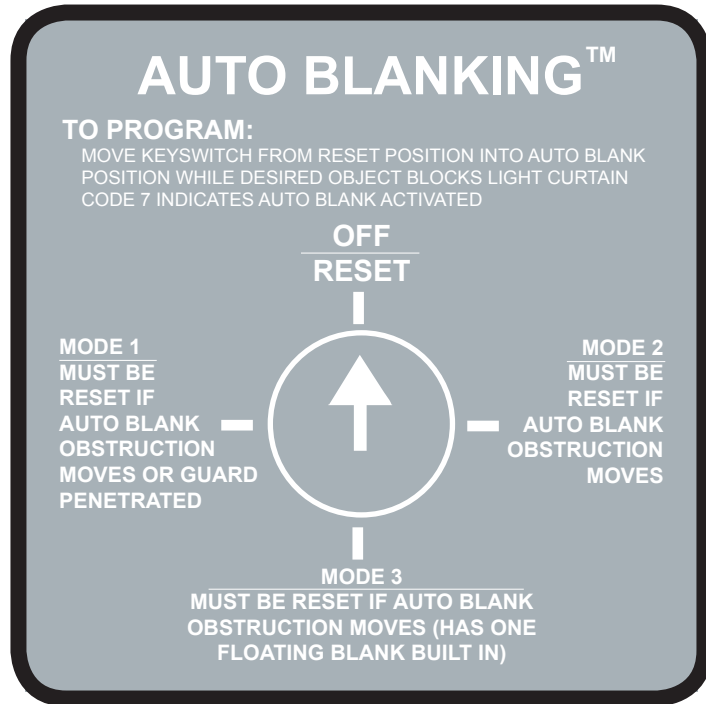

## Auto-Blanking - (AB) Option

The advanced “Auto Blank” option is unique because it will automatically blank out only the required number of beams needed to accept an obstruction such as a conveyor, bracket, or fixture. The unit is easily programmed by a supervisory controlled four-position keyed selector switch located on the front panel of the MicroGuard Controller (shown left). The “Auto Blank” method of blanking is much safer than DIP switch or master/slave blanking systems because only the areas of the obstruction will be blanked. This feature prohibits unsafe oversizing of the blanked area commonly found throughout the industry on manually blanked systems. “Auto Blank” also **eliminates the need** to count beams and to locate where and what beams are to be shut off to obtain the correct beam elevation to accept an obstruction. This information is displayed on the message display of the controller. “Auto Blank” will also watch the obstruction and, if it moves or is removed, will go into a “machine stop mode” to prevent further machine operation. This is an additional safety feature not available on manually blanked units. These features truly enhance production while providing the ultimate in safety.

When the key switch is turned to the “Auto Blank” function, the “External Diagnostic Message Display” will show the number of blocked beams and where the obstruction is in the light curtain, then verify that the obstruction is being monitored. This is required information for the depth penetration factor and for proper installation of any safety light curtain.

The versatile “Auto Blank” (AB) blanking series includes:

- Constant scan light curtain
- One beam floating blank built-in plus “Auto Blank” capability
- Two “Auto Blank” modes - up to 4” blanked out (larger sizes available upon request) but need not be sequential
  - A. One “Auto Blank” mode with keyed reset when guarded zone is penetrated
  - B. One “Auto Blank” mode with automatic reset when guarded zone is penetrated

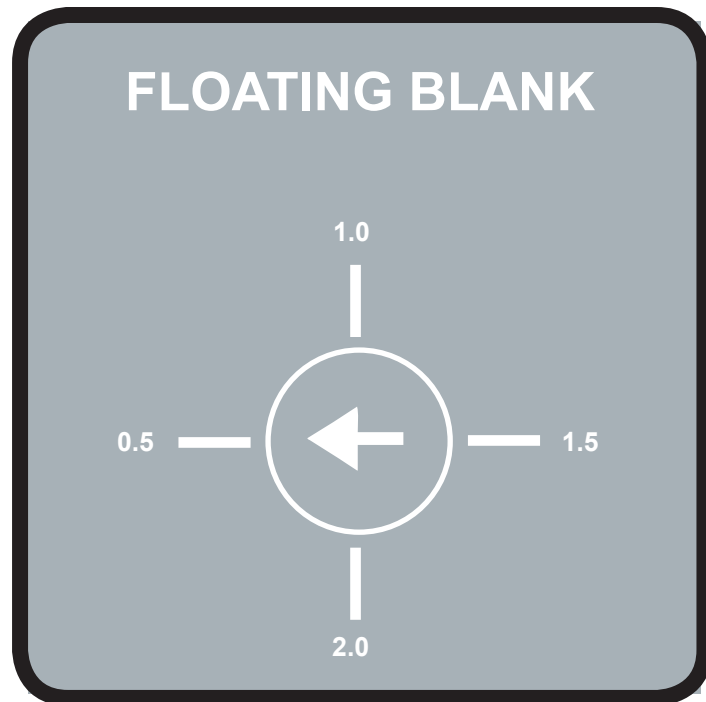

## Floating Blank - (8K) Option

The “Floating Blank” option provides the flexibility necessary to effectively guard all types of equipment that require multiple floating beams. This is quite common in the fabricating industry where the work piece moves.

The “Floating Blank” permits work pieces to be formed vertically or horizontally through the guarded area without shutting down the machine. Entry into the protected area by the operator or passerby will prevent the start or, if the machine is in motion, will provide a signal to stop the machine.

The “Floating Blank” is controlled by a keyed selector switch that will allow a work opening of 2” (51mm) based on 1/2” (13mm) increments (shown left). This information is displayed on the message display of the controller. Blanking adjustments required when die heights change are not necessary. The “Floating Blank” light curtain automatically adjusts to the various feed positions providing **production with protection.**

The “Floating Blank” (8K) Option includes:

- |               |                               |
|---------------|-------------------------------|
| 1/2” (13mm)   | - Constant scan light curtain |
| 1” (25mm)     | - One floating beam           |
| 1-1/2” (38mm) | - Two floating beams          |
| 2” (51mm)     | - Three floating beams        |

# Dimensions

## Pylons with Fixed Mounting Brackets

Model	DIM A (In/mm)	DIM B (In/mm)	DIM C (In/mm)	DIM D (In/mm)
MG-04	3.50 / 89	7.20 / 183	5.35 / 136	8.20 / 208
MG-08	7.50 / 190	11.20 / 284	9.35 / 237	12.20 / 310
MG-12	11.50 / 292	15.20 / 386	13.35 / 339	16.20 / 411
MG-16	15.50 / 394	19.20 / 488	17.35 / 441	20.20 / 513
MG-20	19.50 / 495	23.20 / 589	21.35 / 542	24.20 / 615
MG-24	23.50 / 597	27.20 / 691	25.35 / 644	28.20 / 716
MG-28	27.50 / 698	31.20 / 792	29.35 / 745	32.20 / 818
MG-32	31.50 / 800	35.20 / 894	33.35 / 847	36.20 / 919
MG-36	35.50 / 902	39.20 / 996	37.35 / 949	40.20 / 1021
MG-40	39.50 / 1003	43.20 / 1097	41.35 / 1050	44.20 / 1123
MG-44	43.50 / 1105	47.20 / 1199	45.35 / 1152	48.20 / 1224
MG-48	47.50 / 1207	51.20 / 1300	49.35 / 1253	52.20 / 1326
MG-52	51.50 / 1308	55.20 / 1402	53.35 / 1355	56.20 / 1427
MG-56	55.50 / 1410	59.20 / 1504	57.35 / 1457	60.20 / 1529
MG-60	59.50 / 1511	63.20 / 1605	61.35 / 1558	64.20 / 1631
MG-64	63.50 / 1613	67.20 / 1707	65.35 / 1660	68.20 / 1732

(Incremental additives for longer pylons available)

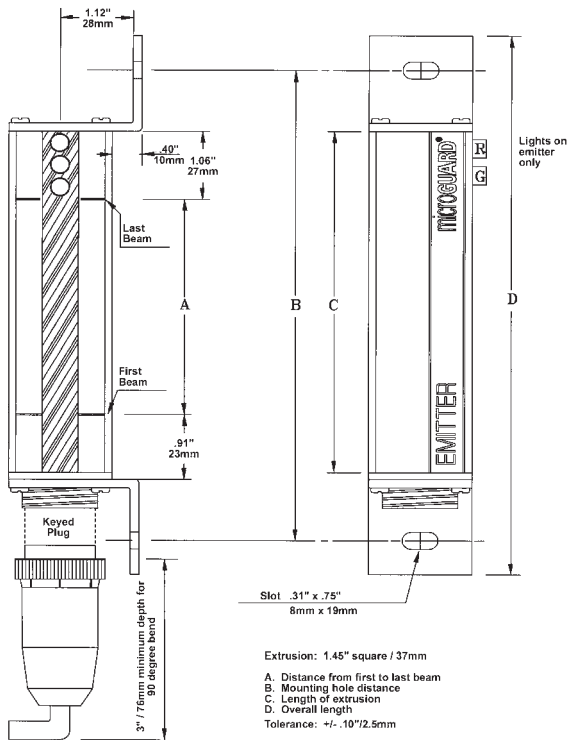

## Pylons with Swivel Mounting Brackets

Model	DIM A (In/mm)	DIM B (In/mm)	DIM C (In/mm)	DIM D (In/mm)
MG-04	3.50 / 89	7.93 / 201	5.35 / 136	8.93 / 227
MG-08	7.50 / 190	11.93 / 303	9.35 / 238	12.93 / 328
MG-12	11.50 / 292	15.93 / 405	13.35 / 339	16.93 / 430
MG-16	15.50 / 394	19.93 / 506	17.35 / 441	20.93 / 532
MG-20	19.50 / 495	23.93 / 608	21.35 / 542	24.93 / 633
MG-24	23.50 / 597	27.93 / 709	25.35 / 644	28.93 / 735
MG-28	27.50 / 698	31.93 / 811	29.35 / 745	32.93 / 836
MG-32	31.50 / 800	35.93 / 913	33.35 / 847	36.93 / 938
MG-36	35.50 / 902	39.93 / 1014	37.35 / 949	40.93 / 1040
MG-40	39.50 / 1003	43.93 / 1116	41.35 / 1050	44.93 / 1141
MG-44	43.50 / 1105	47.93 / 1199	45.35 / 1152	48.93 / 1224
MG-48	47.50 / 1206	51.93 / 1319	49.35 / 1253	52.93 / 1344
MG-52	51.50 / 1308	55.93 / 1421	53.35 / 1355	56.93 / 1446
MG-56	55.50 / 1409	59.93 / 1522	57.35 / 1457	60.93 / 1548
MG-60	59.50 / 1511	63.93 / 1624	61.35 / 1558	64.93 / 1649
MG-64	63.50 / 1613	67.93 / 1725	65.35 / 1660	68.93 / 1751

(Incremental additives for longer pylons available)

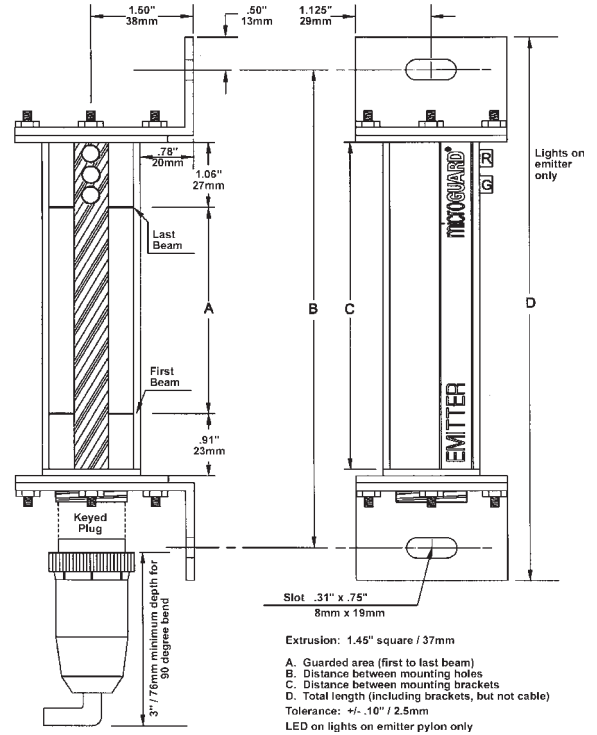

## Metal Box Controller Module

For *multiple light curtain controllers*, the Emitter pylons are plugged into the top of the enclosure and the Receivers are plugged into the bottom as shown. The holes on the top of the box are mirror images of the bottom holes. For *single light curtain controllers*, the Emitter and Receiver pylons are both plugged into the bottom as shown.

Tol. +/- 0.10 inches / 2.54 mm

Dim	Single	Multiple
A	7" / 178mm	8" / 203mm
B	4" / 102mm	7" / 178mm
C	8" / 203mm	9" / 229mm
D	4" / 102mm	4" / 102mm
E	8.65" / 220mm	9.85" / 250mm

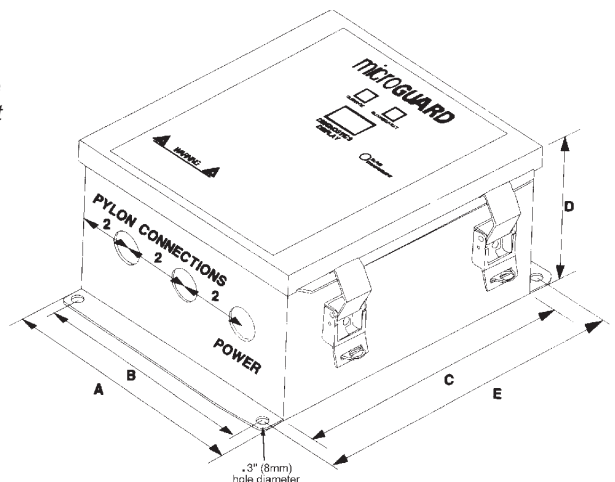

# Accessories

## Cornering Mirror Dimensions

Through the use of cornering mirrors, multiple sides or work envelopes can be guarded which enhance safety and down-time related to mechanical and electrical interlock systems. Be sure to include a 5% reflectivity loss per mirror when calculating total scanning distance of light curtain.

**Note:** Mirrors are surface coated.

MODEL	DIM A (in/ mm) (hole to hole)	DIM B (in/mm) (mirror length)	DIM C (in/mm) (total length)
MGM-04	7.45 / 189	6.25 / 159	8.50 / 216
MGM-08	11.45 / 291	10.25 / 260	12.50 / 318
MGM-12	15.45 / 392	14.25 / 362	16.50 / 419
MGM-16	19.45 / 494	18.25 / 464	20.50 / 521
MGM-20	23.45 / 596	22.25 / 565	24.50 / 622
MGM-24	27.45 / 697	26.25 / 667	28.50 / 724
MGM-28	31.45 / 799	30.25 / 768	32.50 / 826
MGM-32	35.45 / 900	34.25 / 870	36.50 / 927
MGM-36	39.45 / 1002	38.25 / 972	40.50 / 1029
MGM-40	43.45 / 1104	42.25 / 1073	44.50 / 1130
MGM-44	47.45 / 1205	46.25 / 1175	48.50 / 1232
MGM-48	51.45 / 1307	50.25 / 1276	52.50 / 1334
MGM-52	55.45 / 1408	54.25 / 1378	56.50 / 1435
MGM-56	59.45 / 1510	58.25 / 1480	60.50 / 1537
MGM-60	63.45 / 1612	62.25 / 1581	64.50 / 1638
MGM-64	67.45 / 1713	66.25 / 1683	68.50 / 1740

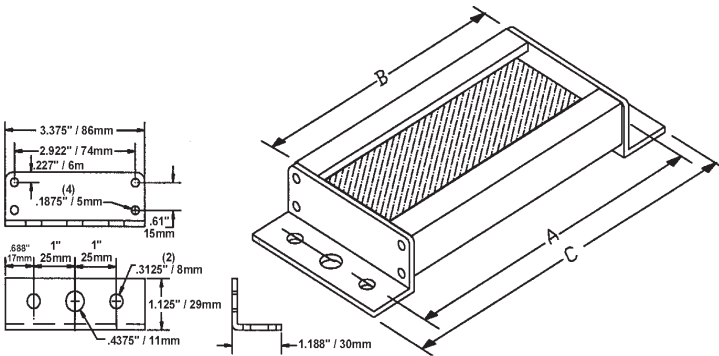

## Pedestal Dimensions (Model 8000)

The heavy duty, all-welded steel pedestal for mounts can be used for mounting either the emitter pylons, receiver pylons, and/or cornering mirrors. Sliding mounts on the pedestal are universal in design and are supplied standard. Unique floating base on pedestal is designed to compensate for uneven floors.

**Note: Pedestals must be bolted to the floor after installation; they must not be movable.**

- 1) Sliding mounts supplied
  - 2) Standard height = 72" (1829mm) Model 8000  
*Optional 96" (2438mm), Model 8096*
  - 3) Painted OSHA yellow
  - 4) Pedestal - 12 gauge steel  
Base Plate - .25" (6mm) steel plate
- Ordering Procedure:** Specify Pedestal Model # and Quantity

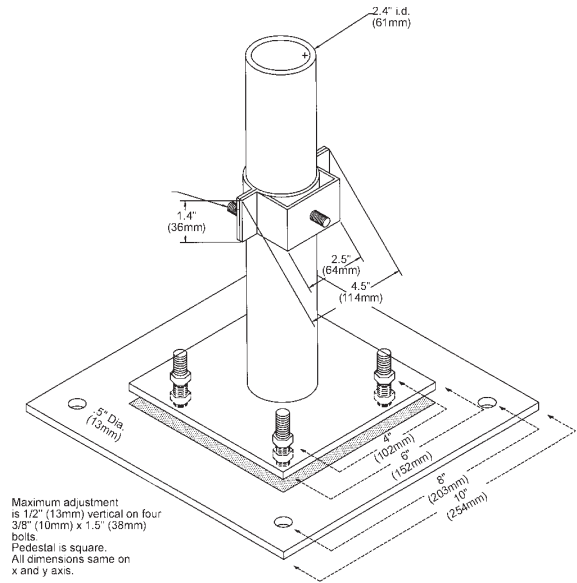

## Model 9000 and 9500 Mounting Brackets

Excellent method of mounting the light guard for press brakes or when the light guard is to be moved for die setups or machine maintenance. Model 9000 consists of three 180-pivot points along with light guard diagonal movement capability for virtually unlimited light guard positioning. Two-inch square tubing 3/16" thick painted OSHA yellow which mounts directly onto the machine housing and makes for a heavy duty yet versatile mounting bracket. Model 9500 consists of two 180-pivot points and one adjustable length arm.

### Model 9000 Swing Arm Brackets

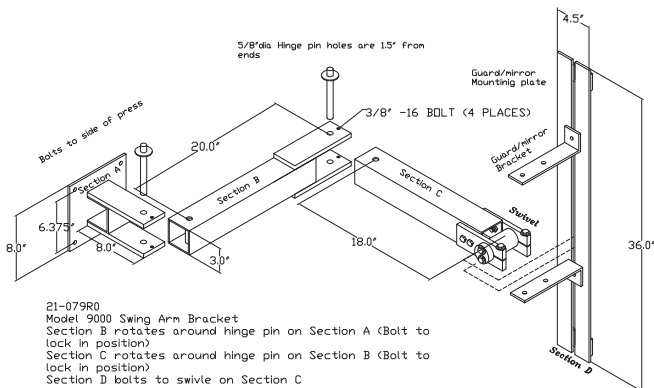

### Model 9500 Swing Arm Brackets

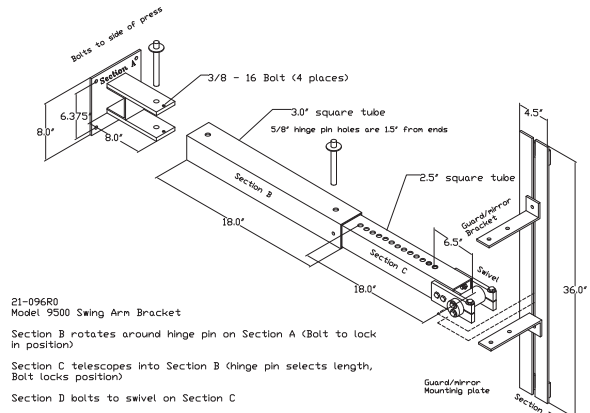

21-079R0  
Model 9000 Swing Arm Bracket  
Section B rotates around hinge pin on Section A (Bolt to lock in position)  
Section C rotates around hinge pin on Section B (Bolt to lock in position)  
Section D bolts to swivel on Section C

21-096R0  
Model 9500 Swing Arm Bracket  
Section B rotates around hinge pin on Section A (Bolt to lock in position)  
Section C telescopes into Section B (hinge pin selects length, Bolt locks position)  
Section D bolts to swivel on Section C



# Ordering Procedure

# microGUARD®

Example  
Part #

MG	-	04	-	OF	-	20	-	(Options)
Light Curtain Controller Module Housing		Pylon Size		Light Curtain Style and Beam Spacing		Scanning distance in feet-20' (6.1m) standard, 50' (15.24m) maximum		

## Light Curtain Controller Module Housing

- MG** - NEMA 12 & 13 (IP 64) stand alone Metal Box Controller Module
- DR** - 35mm DIN-rail Mountable Controller Module (24VDC Input Power Only)

## Pylon Sizes (Protected Area)

- 1/2" (13mm) Beam Spacing: 04,08,12,16,20,24,28,32,36,40,44,48,52,56,60,64
- 1" (25mm) Beam Spacing: 04,08,12,16,20,24,28,32,36,40,44,48,52,56,60,64,68,72,76,80,84,88,92,96,100,104,108,112,116,120

## Light Curtain Style and Beam Spacing

### 1/2" (13mm) Spacing of Beams

- OF** - Constant scan - no blanking.
- 1F** - 1 beam floating blank built-in.
- 8K** - Up to 3 beam floating blank adjustable by the use of a keyswitch removable in all positions. Capable of constant scan or one, two, or three floating beams.
- AB** - Includes constant scan light curtain, one beam floating blank, and two auto blank modes.
- CE** - No blanking, 24VDC input power, 2° angle of divergence, and CE certified (designed to conform to the European Market and worldwide IEC 61496 Parts 1 & 2 Standards).

### 1" (25mm) Spacing of Beams

- OF1** - Constant scan - no blanking.
- 1F1** - 1 beam floating blank built-in.
- 8K1** - Up to 3 beam floating blank adjustable by the use of a keyswitch removable in all positions. Capable of constant scan or one, two, or three floating beams.
- AB1** - Includes constant scan light curtain, one beam floating blank, and two auto blank modes.
- CE1** - No blanking, 24VDC input power, 2° angle of divergence, and CE certified (designed to conform to the European Market and worldwide IEC 61496 Parts 1 & 2 Standards).

## Options (Add underlined suff x to part number)

### AVAILABLE ON BOTH METAL BOX & DIN-RAIL CONTROLLERS

- SMB** - **Swivel Mounting Brackets for Pylons:** Replaces the fixed mounting brackets normally supplied. Provides a 360° rotation of pylons.
- MO** - **Guarding Mute-Out:** Mutes out the light curtain during the non-hazardous portion of the machine cycle.
- DN** - **DeviceNet™:** Fieldbus network compatible.
- Extended Range Units:** 21' (6.4m) to 35' (10.67m) scanning distances (specify desired scanning distance).

### AVAILABLE ON THE METAL BOX CONTROLLER

- LR** - **Resettable Latching Relays:** Requires the light curtain to be manually reset every time the sensing field is penetrated (*built-in standard on the DIN-rail Controller Module*).
- SC** - **Single Controller for Multiple Light Curtains:** Cost effective approach when a machine requires multiple light curtains. All curtains are controlled by a single MicroGuard controller. Up to four sets of pylons can be connected to the controller.
- ES** - **Emergency Stop Input:** E-Stop input requiring the MicroGuard to issue a stop command (*built-in standard on the DIN-rail Controller Module*).
- 24VDC** - **24VDC Input Power:** Required for 24VDC input power.
- 220VAC** - **220VAC Input Power:** Required for 220VAC input power.

### AVAILABLE ON THE DIN-RAIL CONTROLLER

- RSD** - **DIN-rail Remote Status Display (RSD):** Remote mounting plate providing a single location to mount the following on existing panel door: light curtain scrolling diagnostic message display, blanking option keyswitch (if applicable), and status indicator lights (all styles).
- CI** - **Cincinnati Interface:** Requires the MicroGuard to issue a stop command every machine cycle (*built-in standard on the Metal Box Controller Module*).
- AO** - **Analog Output for Non-Safety Applications:** -10VDC to +10VDC or 0VDC to +10VDC.

**EXTRA PYLON PROTECTION (OPTIONAL)**

- PT** - **Polycarbonate tube** which will encase the pylons for high impact protection.
- AT** - **Acrylic Tube** which will encase the pylons for protection from caustic and/or chemical agents.

## Formula for calculating light curtain safety distance

The effective sensing field of the device shall be located at a distance from the nearest recognized hazards such that the operator or others cannot reach the hazard with a hand or other body part before cessation of motion during the hazardous portion of the machine cycle.

The point at which a device responds to an intrusion may vary. The devices should be located or adjusted such that the device always responds to the intrusion at or prior to the safety distance. Care should be exercised when installing the device to ensure that it does not detect false signals from other devices in the area.

Usually the electro-optical presence-sensing device is used in a manner that provides a protected zone in front of the primary work area with auxiliary devices or guards used to protect secondary access areas. In some cases, however, mirrors may be used in conjunction with the device to provide 2-, 3-, 4-, or 5-sided protection.

The machine stop time should be measured with the machine running at its fastest speed with its heaviest die or tooling and the stop time being measured at the 90° position in the downstroke.

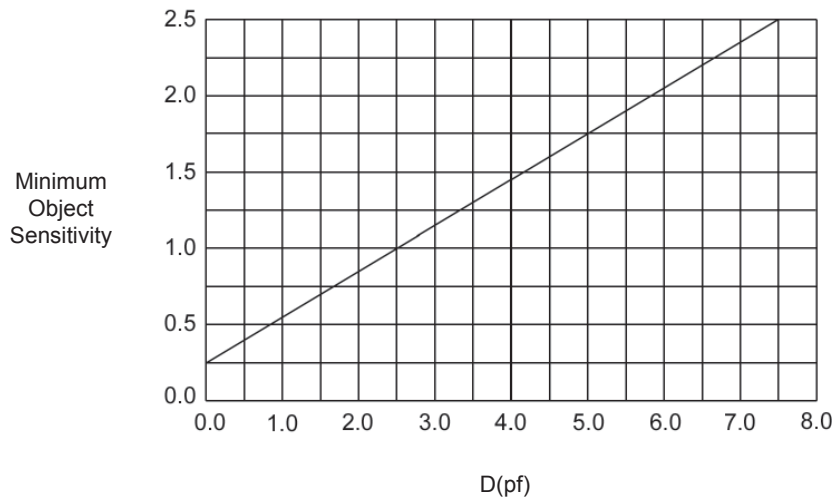

The following formula should be used when calculating the safety distance:

$$D_s = K \times (T_s + T_c + T_r + T_{bm}) + D(pf)$$

- D<sub>s</sub>** = Minimum safety distance between the device and the nearest point of operation hazard (in inches).
- K** = Hand speed constant. This value has been determined by various studies and, although these studies indicate speeds of 63 in/sec to over 100 in/sec, they are not conclusive determinations. The employer should determine this value by considering all factors, including physical ability of the operator.
- T<sub>s</sub>** = Stop time of the machine tool measured by a stop time measurement device.
- T<sub>c</sub>** = Response time of the control system (usually is taken care of by the measurement device).
- T<sub>r</sub>** = Response time of the presence-sending device and its interface, if any, as stated by the manufacturer or measured by the employer.
- T<sub>bm</sub>** = Additional time allowed for the brake monitor to compensate for variations in normal stopping time.
- D(pf)** = Depth Penetration Factor. Added distance as indicated by the above chart. The minimum object sensitivity is stated by the manufacturer.

## Additional products to achieve your **Total Safety Solution!!!**

- Safety Light Curtains (All Types and Styles)
- Universal Safety Controller HUB / Safety PLC
- Safety Mat Systems and Controls
  - Area Guarding Systems
  - NSD Safety Mat Systems
  - STTS Safety Mat Systems
  - Direction of Travel Mats
  - High-Temp Welding Mats
- Ergonomic Palm Buttons
  - UltraTouch Palm Buttons
- Safety Interlock Switches (including explosion proof)
- Customized "control reliable" controls for dual solenoid activated pneumatic and hydraulic valve applications
- Fencing with Interlocks
- E-Stop Buttons
- Stack Lights

- Energy Isolation and Single Point Lockout Systems
- Plant Surveys, Risk Assessment & Installation Services
- Customized Control Panels; Stainless Steel enclosures available for all products

### **Punch Press / Metal Stamping Industry**

- Resolver or Rotary Cam Based Clutch / Brake Controls - OSHA/ANSI Compliant
- Punch Press Automation Controllers
- Time-Based Brake Monitors
- Programmable Limit Switches
- Die Protection & Tonnage Monitoring Systems
- Servo Feed Interfaces

### **Press Brake Guarding and Controls**

- Press Brake Guarding for Mechanical, Air Clutch and Hydraulic Press Brakes
- Press Brake Control Systems



# PINNACLE

S Y S T E M S , I N C .

[www.pinnaclesystems.com](http://www.pinnaclesystems.com)

### **Sales and Marketing Office**

P.O. Box 100088  
Pittsburgh, PA 15233

Toll Free: (800) 569-7697  
Phone: (412) 262-3950  
Fax: (412) 262-4055

[sales@pinnaclesystems.com](mailto:sales@pinnaclesystems.com)

### **Manufacturing and Service Center**

3715 Swenson Avenue  
Saint Charles, IL 60174

Phone: (630) 443-9320  
Fax: (630) 443-9346

[service@pinnaclesystems.com](mailto:service@pinnaclesystems.com)

We have designed our equipment to the very highest performance and safety standards known to the current technological state of the art, as evidenced by our U.S.A. and foreign patents issued and pending. However, the installation, usage, and suitability, and fitness of our equipment for any purpose, known or unknown, is interdependent upon the performance of other equipment not manufactured, installed, secured or maintained by Pinnacle Systems, Inc.

We cannot and do not accept responsibility for any overall system performance when factors such as these, are beyond our control.