

# Model CA Cascading Safety Light Curtain

Cascading Safety Light Curtains  
provide multiple plane guarding  
(x, y and z).

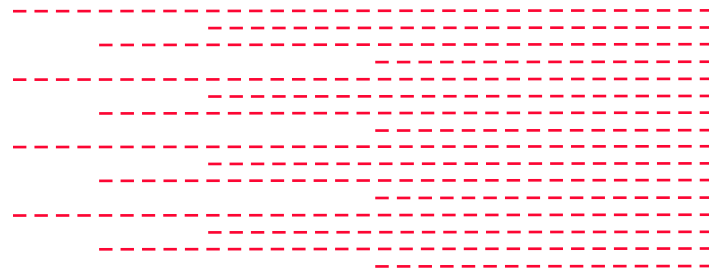
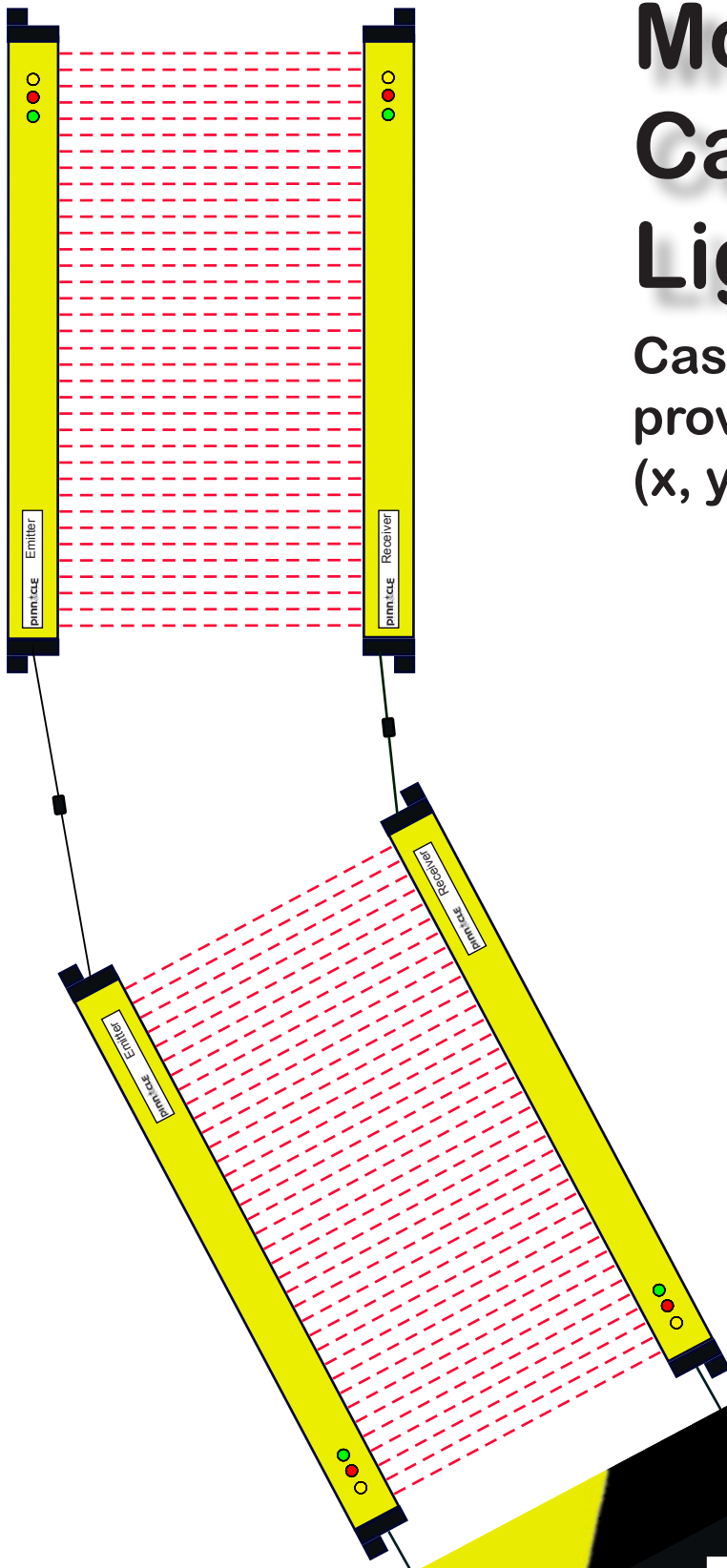

**PINNACLE**  
S Y S T E M S , I N C .

*Safety Sensors and Controls for Industrial Machine Guarding Systems*

[www.pinnaclesystems.com](http://www.pinnaclesystems.com)

# The Ultimate in Safety – Quality – Value - Flexibility

Cascading safety light curtains provide the user the ability to connect additional sets of light curtains by daisy chaining multiple emitters and receivers together. The interconnecting cables are factory supplied and the user defines length. The cascading of safety light curtains provides multiple areas of guarding in any plane (X, Y, Z), while utilizing the control reliable dual safety outputs from the Category 4 safety device for the safety outputs to the machine control. The ability to guard multiple areas on irregular shaped machines by cascading safety light curtains reduces wiring and provides a lower cost yet effective machine guarding solution.

The Model CA Cascading Safety Light Curtain is an infrared safety light curtain that is designed to the IEC 61496 standard. When properly installed, it protects the machine operator by passing an invisible infrared light beam across an area to be guarded and examining whether or not the light beam(s) are blocked. If the light beam(s) are blocked, monitored solid state outputs will open, issuing a "STOP" command to the machines normally closed (N.C.) "STOP" circuit. The Model CA System is composed of transmitting units (EMITTERS), and receiving unit (RECEIVERS). The entire system is control reliable Category 4 (per IEC 61496). A single fault anywhere within the Model CA will not prevent at least one of the solid state outputs from opening up, (allowing a "STOP" command) when either a beam is broken or an internal fault occurs.

## **Theory of operation.**

The Model CA Cascading Safety Light Curtain protects an area by projecting a curtain of infrared light. The infrared emitters and receivers face each other across the field to be protected. Each LED pair is spaced along the length of the pylons at regular intervals from .5" (12mm), up to 8" (203mm) depending on the application. The smaller spacing are for finger guarding, the larger spacing are for body protection. The emitter/receiver pairs are scanned sequentially (one at a time) by a very short pulse of infrared light starting from bottom (cable end), and working up to the end, until every beam pair has been scanned. Two 16 bit computers in the first emitter pylon and two 16 bit computers in the first receiver pylon control the operation, as well as cross check each pylon.

## **The System.**

The Model CA Cascading Safety Light Curtain employs infrared technology in a small sealed NEMA 4 (IP 67) aluminum housing with an infrared passing (daylight filtering) acrylic lens. This system provides harmless invisible protection and an unobstructed view of the guarded area. There are two parts to the Model CA: An Emitter pylon and a Receiver pylon. The Emitter pylon has no outputs. The Receiver pylon contains two monitored solid state 24vdc outputs. Both pylon sets are synchronized to each other electronically as they are connected together with the interconnect cables to the top and bottom of the next set of pylons.

## **System Safety.**

The Model CA Cascading Safety Light Curtain incorporates redundant, and diverse technology that provides a backup for every system that could cause an unsafe condition.

## **External Device Monitoring (EDM).**

A method in which the Model CA Category 4 cascading safety light curtain logic monitors the state of various external control devices. The control devices are external and not part of the Model CA light curtain pylons. A lockout or stop signal will result if an unsafe state is detected in an external device. The External Device Monitoring (EDM) is an optional function of the Model CA safety light curtain for monitoring the status of external devices such as gate and door switches, safety switches or the main control element of the drive (MPCE). Solid state outputs are turned on separately to be checked and to assure neither output has been shorted, before fully turning on.

## **Design Criteria.**

Designed to meet IEC 61496-1 & 2, UL 1998, UL subject 491, OSHA, ANSI, CSA, ANSI-RIA R15.06-1999

Microprocessor redundancy for both Emitter and Receiver pylons

Redundant, monitored, 24vdc solid state outputs (PNP)

Watchdogs on CPU's and outputs prevent unintentional output during lockups.

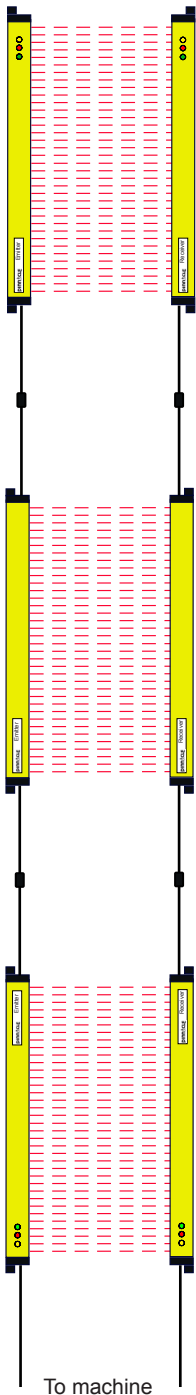

# Remote Status Display and Blanking Options

## Remote Status Display

The optional Remote Status Display (RSD) may be used in conjunction with the Model CA Cascading Safety Light Curtain. The RSD provides the machine operator and front line supervisor immediate system status and diagnostics when the Model CA is mounted inside the machine control panel. The RSD also controls all blanking options directly from the panel location where it is installed.

Remote Status Display (RSD) Components:

- Red/Green/Yellow indicator lights
- Diagnostic scrolling message display with 5' (1.5m) of connector cable
- Keyed selector switch and yellow blanking active indicator supplied if blanking is used

The RSD components are mounted on a steel plate and are designed to be exterior panel mounted. The RSD option enhances safety and is a time saver at machine set-up and when maintenance diagnostics are required.

### Cincinnati Interface

Description: The Cincinnati Interface is provided to allow an external device to determine if the light curtain is still capable of shutting down the safety control circuit. The Cincinnati Interface allows an external device to override the light curtain and initiate a RED condition and open up the standard output relay contacts.

**Application: Cincinnati Press, PLC**

- **Manual Latching Relay Provision**

## Blanking Options

### Floating Blank - (8K) Option

The "Floating Blank" option provides the flexibility necessary to effectively guard all types of equipment that require multiple floating beams. This is quite common in the fabricating industry where the work piece moves.

The "Floating Blank" permits work pieces to be formed vertically or horizontally through the guarded area without shutting down the machine. Entry into the protected area by the operator or passerby will prevent the start or, if the machine is in motion, will provide a signal to stop the machine.

The "Floating Blank" is controlled by a keyed selector switch that will allow a work opening of 2" (51mm) based on 1/2" (13mm) increments. This information is displayed on the message display of the controller. Blanking adjustments required when die heights change are not necessary. The "Floating Blank" light curtain automatically adjusts to the various feed positions providing production with protection.

*(Continued at the top of the next column)*

The "Floating Blank" (8K) Option includes:

- 1/2" (13mm) - Constant scan light curtain
- 1" (25mm) - One floating beam
- 1 1/2" (38mm) - Two floating beams
- 2" (51mm) - Three floating beams

### Auto-Blanking - (AB) Option

The advanced "Auto Blank" option is unique because it will automatically blank out only the required number of beams needed to accept an obstruction such as a conveyor, bracket, or fixture. The unit is easily programmed by a supervisory controlled four-position keyed selector switch located on the front panel of the RSD Display. The "Auto Blank" method of blanking is much safer than DIP switch or master/slave blanking systems because only the areas of the obstruction will be blanked. This feature prohibits unsafe oversizing of the blanked area commonly found throughout the industry on manually blanked systems. "Auto Blank" also **eliminates the need** to count beams and to locate where and what beams are to be shut off to obtain the correct beam elevation to accept an obstruction. This information is displayed on the message display of the controller. "Auto Blank" will also watch the obstruction and, if it moves or is removed, will go into a "machine stop mode" to prevent further machine operation. This is an additional safety feature not available on manually blanked units. These features truly enhance production while providing the ultimate in safety.

When the key switch is turned to the "Auto Blank" function, the "External Diagnostic Message Display" will show the number of blocked beams and where the obstruction is in the light curtain, then verify that the obstruction is being monitored. This is required information for the depth penetration factor and for proper installation of any safety light curtain. Learned Auto Blank patterns for the Model CA are stored in non-volatile memory for automatic recall at power-up.

The versatile "Auto Blank" (AB) blanking series includes:

- **Constant scan light curtain**
- **One beam floating blank built-in plus "Auto Blank" capability**
- **Two "Auto Blank" modes - up to 4" blanked out (larger sizes available upon request) but need not be sequential**
  - A. **One "Auto Blank" mode with keyed reset when guarded zone is penetrated (latch)**
  - B. **One "Auto Blank" mode with automatic reset when guarded zone is penetrated**

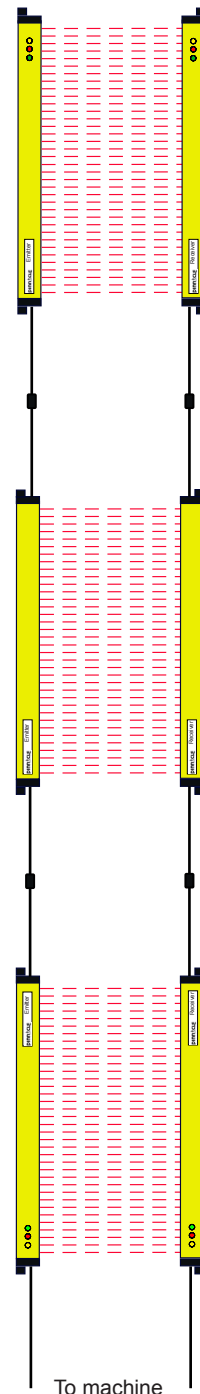

# Model CA

## Pylon sizes to meet all of your Segmented Guarding Needs

4"  
(102 mm)

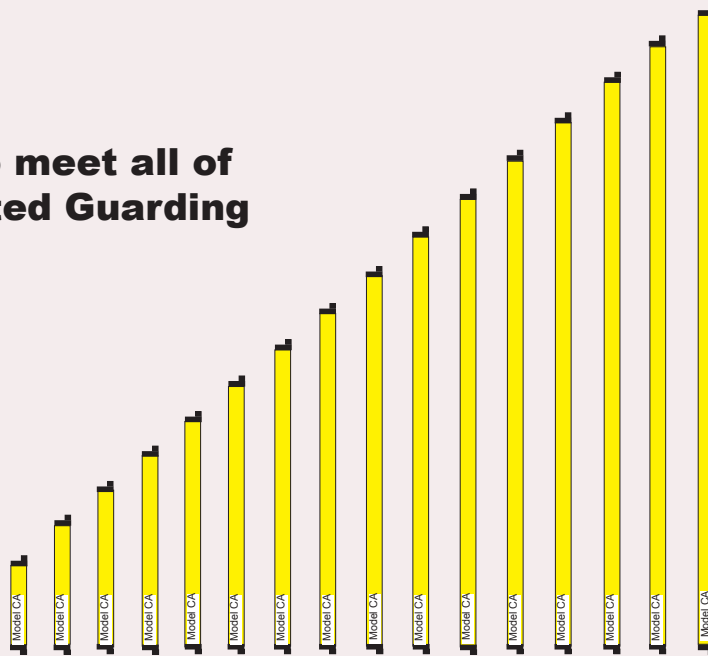

64"  
(1626 mm)

# Safety Relay and Socket Assembly

## Part #52-278 (Two Required)

### DIN-Rail or Back Plate Mounting



Safety Relay

|                                   |                                |
|-----------------------------------|--------------------------------|
| Contact material                  | AgSn O <sub>2</sub> + 0.2µm Au |
| Type of contact                   | Crest contact                  |
| Rated switching capacity          | 250VAC 8A AC1 2'000VA          |
| Electr. Life AC1 (360 cycles/h)   | Approx. 100'00                 |
| Inrush current max.               | 20A for 20ms                   |
| Switching voltage range           | 5 to 250 VDC/VAC               |
| Switching current range*          | 10mA to 8A                     |
| Switching capacity range*         | 0.06VA(W) to 2'000VA           |
| Contact resistance (as delivered) | ≤100m Ω/28V/100mA              |
| *Guide values                     |                                |

- Safety relay with force guided contacts (dry)
- Relay configuration: 2NO/1NC
- Mean coil power 0.75W
- Holding power 0.21W
- EN 50205 type A

- DIN rail socket
- Integrated retaining/ejector handles
- Screw terminals
- Assembly on DIN rail 35mm or with 2xM3 screws



Insert into

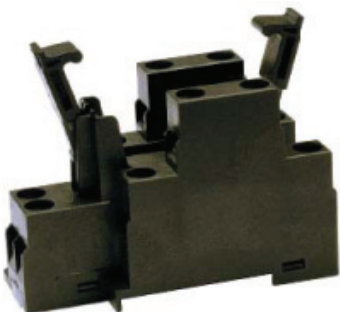

DIN-Rail Socket

| Technical data                     |                      |
|------------------------------------|----------------------|
| Rate current                       | 6A                   |
| Rated voltage                      | 250VAC               |
| Test voltage coil/contacts         | 2'500Veff            |
| Insulation class (IEC 60664-1)     | 250VAC               |
| Creepage resistance                | CTI 250              |
| Weight                             | Approx. 65g          |
| Ambient temperature                | -25°C to +70°C       |
| Cross sections for connection with |                      |
| -wires                             | 2x2.5mm <sup>2</sup> |
| -end sleeves for strands           | 2x1.5mm <sup>2</sup> |
| Torque max.                        | 0.8 Nm               |

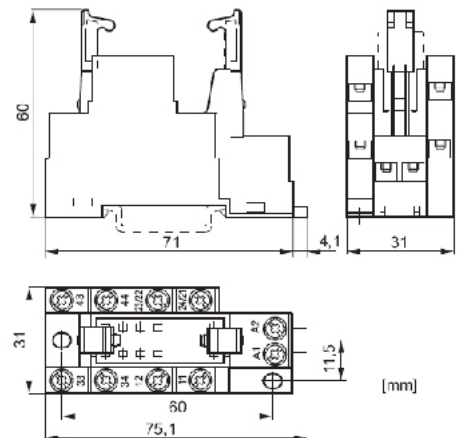

# Specifications and Dimensions

- **Input Power:** Emitter pylon: 24vdc @ .125A  
Receiver pylon: 24vdc @ .125A (solid state outputs are PNP which may draw up to .25A additional)
- **Internal fuses:** Emitter Pylon: F1 @ 1A  
Receiver Pylon: F1 @ 1A, F2 @ 1/2A, F3 @ 1/2A
- **Outputs:** Receiver pylon: monitored, 2 outputs, solid state PNP (24vdc when GREEN, float when RED/off). Max .25A draw each.
- **Indicators:** Emitter pylon: Yellow, Red, Green.  
Receiver pylon: Yellow, Red, Green.
- **Construction:** Painted aluminum extrusion with Acrylic IR lens and Viton Seals providing NEMA 14 (IP 65) protection.  
Optional Polycarbonate tubes (sleeves) over the pylons provides NEMA 4 (IP 65) protection.  
Emitter pylon: Four conductor 24AWG  
Receiver pylon: Six conductor 24AWG  
Pylons: Yellow | Cables: Black
- **Temperature:** 0 to 50c (up to 95% humidity, non-condensing)
- **Safety Software:** 0 to 50c tested to UL1998 and ISO 9001 standards.
- **Pylon Enclosures:** Tested to IEC 60529

- **EMC Testing** to IEC 61000-4 standards.
- **Dimensions:** 1.45" (36.8mm) square X selected length (see tables for lengths)
- **Beam Spacing & Minimum Object Sensitivity (MOS)**  
.5" (12.7mm) .55" (14mm) MOS  
1" (25.4mm) 1.18" (30mm) MOS  
(special order, 4" active area followed by a 4" or 8" gap)
- **Response Time and Scanning Frequency:**  
< 30 mSec total, 10 khz
- **Shock:** Tested to withstand high vibration (using shock mounts)
- **Self-Checking:** Every 15mSec
- **Scanning distance**  
From 1' to 20' standard (1-6m)  
From 21' to 50' (6-15m) extended range (optional)  
The range is stated as a two digit number within the Model #
- **Specials:** Custom designed light curtains for special applications. Consult factory.
- **Surface Mount Technology**
- **One Year Warranty**
- **Made in USA**

Model CA output circuits must be used with either "control reliable" PLC input circuits, or a safety module.

## Pylons with Fixed Mounting Brackets (In/mm)

| Model | DIM A        | DIM B        | DIM C        | DIM D        |
|-------|--------------|--------------|--------------|--------------|
| CA-04 | 3.50 / 89    | 7.20 / 183   | 5.35 / 136   | 8.20 / 208   |
| CA-08 | 7.50 / 190   | 11.20 / 284  | 9.35 / 237   | 12.20 / 310  |
| CA-12 | 11.50 / 292  | 15.20 / 386  | 13.35 / 339  | 16.20 / 411  |
| CA-16 | 15.50 / 394  | 19.20 / 488  | 17.35 / 441  | 20.20 / 513  |
| CA-20 | 19.50 / 495  | 23.20 / 589  | 21.35 / 542  | 24.20 / 615  |
| CA-24 | 23.50 / 597  | 27.20 / 691  | 25.35 / 644  | 28.20 / 716  |
| CA-28 | 27.50 / 698  | 31.20 / 792  | 29.35 / 745  | 32.20 / 818  |
| CA-32 | 31.50 / 800  | 35.20 / 894  | 33.35 / 847  | 36.20 / 919  |
| CA-36 | 35.50 / 902  | 39.20 / 996  | 37.35 / 949  | 40.20 / 1021 |
| CA-40 | 39.50 / 1003 | 43.20 / 1097 | 41.35 / 1050 | 44.20 / 1123 |
| CA-44 | 43.50 / 1105 | 47.20 / 1199 | 45.35 / 1152 | 48.20 / 1224 |
| CA-48 | 47.50 / 1207 | 51.20 / 1300 | 49.35 / 1253 | 52.20 / 1326 |
| CA-52 | 51.50 / 1308 | 55.20 / 1402 | 53.35 / 1355 | 56.20 / 1427 |
| CA-56 | 55.50 / 1410 | 59.20 / 1504 | 57.35 / 1457 | 60.20 / 1529 |
| CA-60 | 59.50 / 1511 | 63.20 / 1605 | 61.35 / 1558 | 64.20 / 1631 |
| CA-64 | 63.50 / 1613 | 67.20 / 1707 | 65.35 / 1660 | 68.20 / 1732 |

(Incremental additives for longer pylons available)

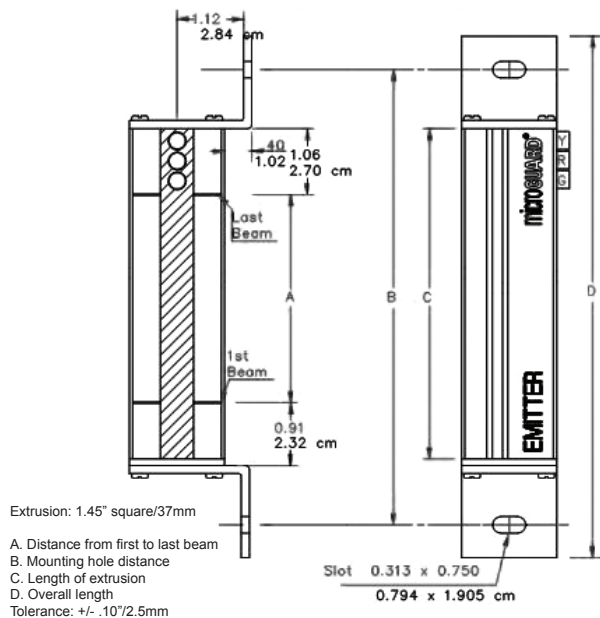

## Pylons with Swivel Mounting Brackets (In/mm)

| Model | DIM A        | DIM B        | DIM C        | DIM D        |
|-------|--------------|--------------|--------------|--------------|
| CA-04 | 3.50 / 89    | 7.93 / 201   | 5.35 / 136   | 8.93 / 227   |
| CA-08 | 7.50 / 190   | 11.93 / 303  | 9.35 / 238   | 12.93 / 328  |
| CA-12 | 11.50 / 292  | 15.93 / 405  | 13.35 / 339  | 16.93 / 430  |
| CA-16 | 15.50 / 394  | 19.93 / 506  | 17.35 / 441  | 20.93 / 532  |
| CA-20 | 19.50 / 495  | 23.93 / 608  | 21.35 / 542  | 24.93 / 633  |
| CA-24 | 23.50 / 597  | 27.93 / 709  | 25.35 / 644  | 28.93 / 735  |
| CA-28 | 27.50 / 698  | 31.93 / 811  | 29.35 / 745  | 32.93 / 836  |
| CA-32 | 31.50 / 800  | 35.93 / 913  | 33.35 / 847  | 36.93 / 938  |
| CA-36 | 35.50 / 902  | 39.93 / 1014 | 37.35 / 949  | 40.93 / 1040 |
| CA-40 | 39.50 / 1003 | 43.93 / 1116 | 41.35 / 1050 | 44.93 / 1141 |
| CA-44 | 43.50 / 1105 | 47.93 / 1199 | 45.35 / 1152 | 48.93 / 1224 |
| CA-48 | 47.50 / 1207 | 51.93 / 1319 | 49.35 / 1253 | 52.93 / 1344 |
| CA-52 | 51.50 / 1308 | 55.93 / 1421 | 53.35 / 1355 | 56.93 / 1446 |
| CA-56 | 55.50 / 1409 | 59.93 / 1522 | 57.35 / 1457 | 60.93 / 1548 |
| CA-60 | 59.50 / 1511 | 63.93 / 1624 | 61.35 / 1558 | 64.93 / 1649 |
| CA-64 | 63.50 / 1613 | 67.93 / 1725 | 65.35 / 1660 | 68.93 / 1751 |

(Incremental additives for longer pylons available)

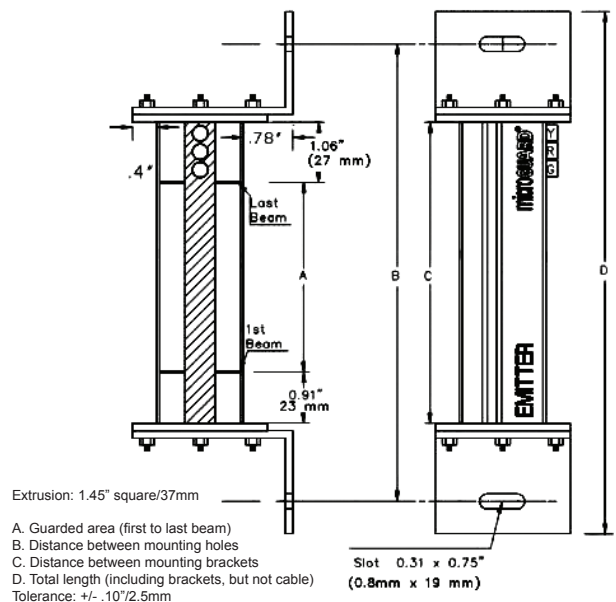

# Ordering/Pricing Procedure

21' (6.3m) input power and safety output cable with connector supplied standard.  
Max length is 45'.  
Consult factory for longer lengths.

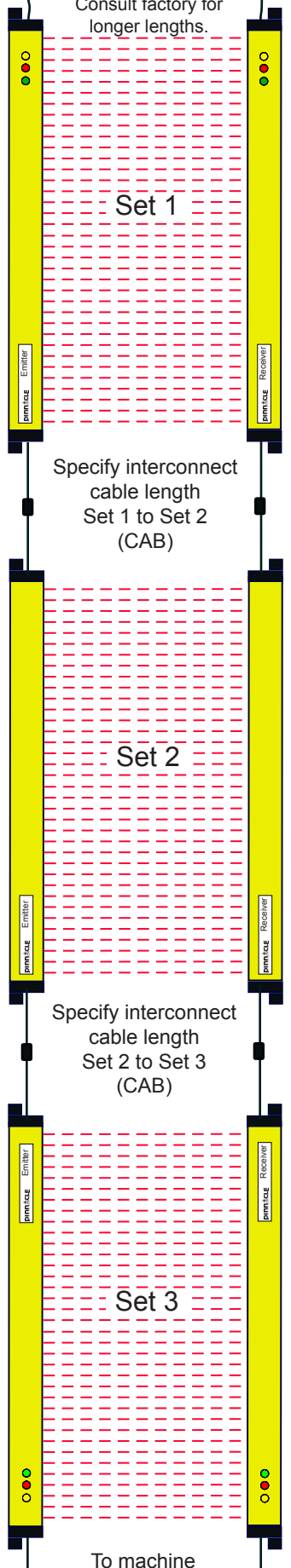

## Ordering/Pricing Procedure for Pylons

| <b>CAS</b>              | Set 1   | Set 2 | Set 3 | Set 1                                 | Set 2 | Set 3 |   |  |
|-------------------------|---|-------|-------|---------------------------------------|-------|-------|---|--|
| <b>Cascading System</b> | <b>Pylon Guarded Zone in inches</b>                   |       |       | <b>Beam Spacing Options</b>           |       |       | <b>Light Curtain Style or Blanking*</b> | <b>Scanning Distance In Feet</b>         |
|                         | 4" (102mm) to 120" (3,048mm) in 4" (102mm) increments |       |       | .5" (13mm)<br>1" (25mm)<br>4" (100mm) |       |       | OF<br>1F<br>8K<br>AB                    | 20' (6.1m) standard, 50' (10.7m) maximum |

\*Light Curtain Style or Blanking Description

**OF**  
**1F**  
**8K**

- Constant scan - no blanking
- 1 beam floating blank built-in.
- Up to 3 beam floating blank adjustable by the use of a supervisory keyswitch removable in all positions. Capable of constant scan or one, two or three floating beams. (Requires RSD option)

**AB**

- Includes constant scan light curtain, one beam floating blank and two auto blank modes. (Requires RSD option)

If modifications are needed, please consult factory.

## Options

**SMB**

- **Swivel Mounting Brackets for Pylons:** Replaces the fixed mounting brackets normally supplied. Provides a 360° rotation of pylons.

**PT**

- **Polycarbonate tube** which will encase the pylons for high impact protection.

## Ordering/Pricing Procedure for Cables

| <b>CAB</b>                     | <b>21</b>   |  |                       |
|--------------------------------|---|--|-----------------------|
| <b>Cascading System Cables</b> | <b>21' (6.3m) Supplied Standard</b>                               | <b>Set 1 to Set 2</b>  | <b>Set 2 to Set 3</b> |
|                                | <b>Input power (24VDC) and Safety Output Cable with Connector</b> | <b>Interconnecting Cables with Connector</b>   |                       |
|                                |   | Max 6' (1.8m) between sets<br>24' (7.3m) max cumulative interconnect length in system. |                       |
|                                | <b>200' Maximum Length</b>  |  |                       |

Please note that both the Pylons and Cables part numbers must be submitted to complete the order.

- Pylons can be hard wired together with no connectors if required (consult factory).
- Maximum of 128 beams per system (cumulative).
- Consult factory for larger beam systems or additional segments if needed.

# Accessories

## Cornering Mirror Dimensions

Through the use of cornering mirrors, multiple sides or work envelopes can be guarded which enhance safety and reduce downtime related to mechanical and electrical interlock systems. Include a 15% reflectivity loss per mirror when calculating the total scanning distance of the light curtain.

| Model  | Dim A (hole to hole) | Dim B (mirror)   | Dim C (total)    |
|--------|----------------------|------------------|------------------|
| MGM-12 | 19.45" (494mm)       | 18.25" (464mm)   | 20.50" (521mm)   |
| MGM-18 | 25.45" (646mm)       | 24.25" (616mm)   | 26.50" (673mm)   |
| MGM-24 | 31.45" (799mm)       | 30.25" (768mm)   | 32.50" (825mm)   |
| MGM-30 | 37.45" (951mm)       | 35.25" (895mm)   | 38.50" (978mm)   |
| MGM-36 | 43.45" (1104mm)      | 42.25" (1073mm)  | 44.50" (1130mm)  |
| MGM-42 | 49.45" (1256mm)      | 48.25" (1226mm)  | 50.50" (1282mm)  |
| MGM-48 | 55.45" (1408mm)      | 54.25" (1378mm)  | 56.50" (1435mm)  |
| MGM-60 | 67.45" (1713mm)      | 66.25" (1683mm)  | 68.50" (1739mm)  |
| MGM-72 | 79.45" (2018mm)      | 78.25" (1988mm)  | 80.50" (2045mm)  |
| MGM-84 | 91.45" (2323mm)      | 90.25" (2292mm)  | 92.50" (2350mm)  |
| MGM-96 | 103.45" (2628mm)     | 102.25" (2597mm) | 104.50" (2654mm) |

## Pedestal Dimensions (Model 8000)

The heavy duty, all welded steel pedestal floor mounts can be used for mounting either light curtain pylons or cornering mirrors. Sliding mounts on the pedestal are of universal design and are supplied standard. Unique floating base on pedestal is designed to compensate for uneven floors.

**NOTE: Pedestals must be bolted to the floor, they must not be movable (ANSI B11.19-2003).**

1. Sliding mounts supplied
2. Standard height is 72" (1829mm) - Model #8000  
Optional 96" (2438mm) - Model #8096
3. Painted OSHA yellow
4. Pedestal is 12 gauge steel  
Base Plate is 1/4" (6.35mm) steel plate

### Ordering Procedure

Specify Pedestal Model Number and Quantity

## Safety Light Curtains

*"A system designed specifically for your machine guarding needs"*



|                             | Model MG – Metal Box  | Model DR – DIN-rail  | Model CE – Solid State   |
|-----------------------------|---|--|--|
| <b>Description</b>          | "Thin Profile" with Nema 12 (IP 64) Enclosure and two Quick Disconnect cables | "Thin Profile" with "Intelligent Safety Relay" DIN-rail Controller and 22' (6,705mm) Quick Disconnect cables | "Thin Profile" with Solid State Outputs and two 21' (6,096mm) Quick Disconnect cables with multi-directional pigtailed |
| <b>Controller Enclosure</b> | Metal Box   | Gray Polycarbonate (IP 40) UL94 V-1  | N/A  |
| <b>Pylon Construction</b>   | Aluminum Extrusion NEMA 4 (IP 65)   | Aluminum Extrusion NEMA 4 (IP 65)  | Aluminum Extrusion NEMA 4 (IP 65)  |
| <b>Input Voltage</b>        | 120VAC, 24VDC, 220VAC   | 24VDC  | 24VDC  |
| <b>Sizes</b>                | 4" (102mm) – 120" (3,048mm) in 4" (102 mm) increments                         | 4" (102mm) – 120" (3,048mm) in 4" (102 mm) increments  | 4" (102mm) – 120" (3,048mm) in 4" (102 mm) increments  |
| <b>Beam Spacing</b>         | 1/2" (13mm) or 1" (25mm) beam centers   | 1/2" (13mm) or 1" (25mm) beam centers  | 1/2" (13mm) or 1" (25mm) or 4" (102mm) beam centers  |
| <b>Blanking Style</b>       |   |  |  |
| Auto Blank                  | Yes   | Yes  | Yes  |
| Floating Blank              | Yes   | Yes  | Yes  |
| <b>Scanning Ranges</b>      | 1' – 50' (.3-16m)   | 1' – 50' (.3-16m)  | 1' – 50' (.3-16m)  |
| <b>Warranty</b>             | 2 Years   | 2 Years  | 1 Year   |

Also Available!

# Extremely Durable Safety Mats Available in Any Shape or Size!

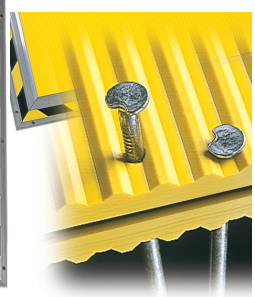
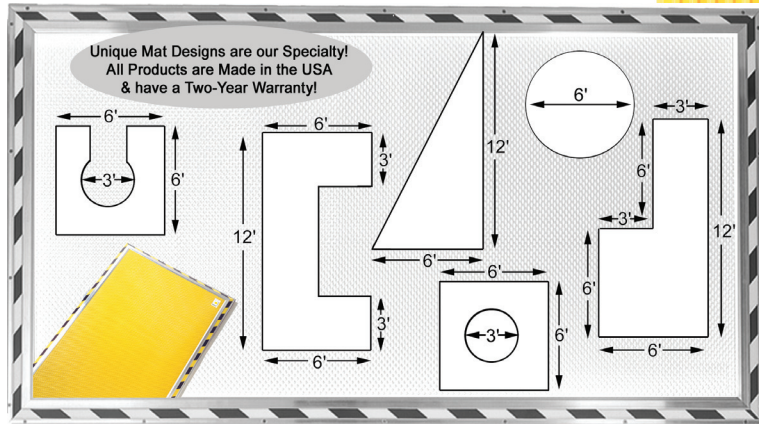

## Additional Products Available:

- Safety Light Curtains
- Press Brake Controls
- Mute Out Packages
- Brake Performance Testers



For more information, visit  
[www.triadcontrols.com](http://www.triadcontrols.com)  
[sales@triadcontrols.com](mailto:sales@triadcontrols.com)

- Safety Light Curtains
- Safety Mat Systems
- Ergonomic Palm Buttons



For more information, visit  
[www.pinnaclesystems.com](http://www.pinnaclesystems.com)  
[sales@pinnaclesystems.com](mailto:sales@pinnaclesystems.com)

- Resolver Based Clutch/ Brake Controls
- Rotary Cam Based Clutch/ Brake Controls
- Punch Press Automation Controllers
- Time Based Brake Monitor



For more information, visit  
[www.pressroomelectronics.com](http://www.pressroomelectronics.com)  
[sales@pressroomelectronics.com](mailto:sales@pressroomelectronics.com)



P.O. Box 9305  
Pittsburgh, PA 15225

Place  
Postage  
Here

Visit us on the web at [www.pinnaclesystems.com](http://www.pinnaclesystems.com)  
[sales@pinnaclesystems.com](mailto:sales@pinnaclesystems.com) | [service@pinnaclesystems.com](mailto:service@pinnaclesystems.com)